

H5 Roadside and Median Barrier Systems

H5.1 Introduction

Barrier systems can be classified into two categories, based on their location and design:

- roadside
- median.

A roadside barrier system is designed to redirect vehicles that impact on only one side of the barrier. It is typically used to shield motorists from natural and man-made hazards located along either side of the edge of highways and ramps, including the left side of divided highways with wide medians. It may also be used to protect vulnerable road users, such as pedestrians and cyclists, and snowmobiles from vehicular traffic under special conditions.

A median barrier system is designed to redirect vehicles that impact on both sides of the barrier system. Median barriers are typically used to separate traffic with high differential speeds and/or to manage access. Common examples of medians include separating the high opposing traffic speeds on divided highways, controlling access between and/or separating traffic on parallel roadways such as service roads and freeway collectors-distributors. The proximity of interchange ramps to the highway sometimes requires a median treatment as well.

Precast concrete barrier systems are movable, segmented, barrier systems that are most commonly used in work zones to protect both motorists and workers. Selected precast concrete barrier systems may also function as permanent barrier systems (roadside or median) if designed and maintained appropriately.

Barrier systems should be designed with consideration for adjacent roadside features. The

selection and design of a barrier system must include consideration of the roadway, shoulder, drainage facilities and the roadside environment of the surrounding area. Together, these elements are designed to function in harmony, maximizing the safety benefits of the highway as a system. Conversely, situations that reduce safety can develop when the interaction of roadside features (including barrier systems) is not given adequate consideration. Poor choices reflecting this include locating barriers behind or on steeper slopes and/or using barrier curb-barrier combinations on higher speed roads. Application restrictions are noted for each barrier system.

The proper performance of barrier systems is heavily dependent on the correct design, installation, maintenance and post-impact repair. Grading and anchorage requirements should also receive proper attention.

To be effective, a barrier system should:

- prevent penetration, vaulting over (overriding), or wedging under (under riding)
- unless otherwise designed, remain substantially intact so that system elements and debris will not pose an undue risk to vehicle occupants or other traffic
- be designed and installed to reduce the risk of system components entering into the passenger compartment (spearing) of the impacting vehicle.

A vehicle-barrier collision should result in the smooth redirection of the impacting vehicle at a low departure angle that will reduce the risk of interacting with other vehicles. Finally, the collision must not result in excessive lateral or longitudinal deceleration to the vehicle occupants.

Since the dynamics of a crash are complex, the most effective means of assessing barrier system performance is through full scale crash tests. By standardizing such tests, barrier system designers can compare the safety performance of alternative designs.

The primary purpose of a barrier system is to reduce the collision severity when the vehicle leaves the roadway and encounters hazards (fixed objects or terrain features) that are less forgiving than striking the barrier system. A barrier system is intended to contain and/or redirect an impacting vehicle.

Barrier systems are categorized on the basis of their design deflection characteristics:

- flexible
- semi-rigid
- rigid.

The design deflection is the distance that a barrier system is expected to move laterally under impact, measured from the face of the system. Rigid systems, as their name implies, do not deflect significantly. Semi-rigid systems generally deflect 1.5 m or less. Flexible systems such as the High Tension Cable System and Alberta Weak Post deflect significantly, up to 3.5 m or more upon impact.

The design deflection of a barrier system is important, in that it determines the minimum separation between the barrier system and the hazard that is being shielded. If the system is placed too close, the impacting vehicle may deflect the barrier system into the hazard, allowing the vehicle to strike the hazard, thereby defeating the purpose of the barrier system.

Barrier systems, whether they are rigid, semi-rigid or flexible, must be of sufficient length and be properly anchored to develop their full strength. For rigid systems, sufficient length and

mass are necessary to prevent the system from being displaced upon impact.

Alberta has adopted the performance requirements for barrier systems based on the *National Cooperative Highway Research Program (NCHRP) Report 350 - Recommended Procedures for the Safety Performance Evaluation of Highway Features*.

All systems must be rated at least as TL-3 for high speed highways (posted speed of 100 km/h or higher) where the AADT > 2500. Discussion on the selection of appropriate barrier systems is provided in **Section H3.2.3.1**.

H5.2 Roadside Barriers

Roadside barrier systems are designed to be impacted on only one side.

In general, the following systems are currently permitted for use on Alberta highways as roadside barrier systems:

- High Tension Cable Barrier Systems (TL-4)
- Alberta Weak Post W-Beam with Wood or Plastic posts* (Not tested under *NCHRP Report 350*, but assumed to be functionally equivalent to TL-3)
- Weak Post Box Beam (TL-3)
- Strong Post W-Beam with Wood, Steel, or Plastic posts (TL-3)
- Modified Thrie Beam (TL-4)
- Precast Single Slope or F-Shape Concrete Barrier (TL-3)
- Cast-in-place or extruded F-Shape Concrete Barrier (TL-4 or TL-5)
- Cast-in-place or extruded Single Slope Concrete Barrier (TL-4 or TL-5).

* The Alberta Weak Post W-Beam system has exhibited satisfactory in-service performance over many years and will continue to be used where appropriate.

For the selection of the appropriate barrier systems, refer to **Section H3.2.3.1**.

Table H5.1 provides a summary of the key dimensions and characteristics of barrier systems used on Alberta highways:

TABLE H5.1 Roadside Barrier Systems Characteristics Summary

Barrier System	Post Type	Category	NCHRP Report 350 Test Level	Design Deflection (m)	Minimum System Length (m)
High Tension Cable System	Steel Post	Flexible	TL-4	Depends on post spacing and choice of system, refer to manufacturer's information (2.1 to 2.4)	Refer to manufacturer's information (varies up to 35 m)
Alberta Weak Post W-Beam ¹	Plastic or Wood	Flexible	N/A	2.5	22.86 (≤ 70 km/h) ¹ 45.72 (≥ 80 km/h) ¹
Weak Post Box Beam	Steel Post	Semi-Rigid	TL-3	1.5	100
Strong Post W-Beam	Plastic Post	Semi-Rigid	TL-3	1.5	50
	Wood or Steel Post	Semi-Rigid	TL-3	0.9	50
Standard Thrie Beam	Steel Post	Semi-Rigid	TL-3	0.6	50
Modified Thrie Beam	Steel Post	Semi-Rigid	TL-4	0.9	50
Precast Concrete Barrier – F-Shape or other approved shape (Temporary installation or special purpose permanent)	N/A	Semi-Rigid (must use crash tested joint between units)	TL-3	0.075 to 1.8	45
Cast-in-place or Extruded Concrete Barrier	N/A	Rigid	TL-4 or TL-5	0.0	30

¹ Minimum length for weak post w-beam does not include length of end treatments. The corresponding speeds are based on design speed.

Drawings for approved roadside barrier systems, including transition information, are provided in **Appendix B** of this guide.

Consult the recommended products list to confirm that the selected end treatments may be used in Alberta. The recommended products list may be accessed on INFTRA's website.

H5.3 Median Barriers

Median Barrier Systems are designed to be impacted from both sides.

The primary purpose of a median barrier system is to reduce the collision severity when the vehicle leaves the roadway and encounters other vehicles (opposing or travelling in the same direction) or hazards (fixed objects or terrain features) that are less forgiving than striking the barrier system. A median barrier system is intended to contain and/or redirect an impacting vehicle.

In general, the following systems are currently allowed for use on Alberta highways as median barrier systems:

- High Tension Cable Barrier Systems (TL-4)
- Weak Post Box Beam (TL-3)
- Strong Post W-Beam with Wood, Steel, or Plastic posts (TL-3)
- Modified Thrie Beam (TL-4)
- Precast F-Shape or Single Slope Concrete Barrier (TL-3)
- Cast-In-Place F-Shape Concrete Barrier (TL-4 or TL-5)
- Cast-In-Place Single Slope Concrete Barrier (TL-4 or TL-5).

To determine the warrant for median barrier, and selection of the appropriate barrier systems, refer to **Section H3.2.3.1**.

Table H5.2 provides a summary of the key dimensions and characteristics of median barrier systems used on Alberta highways:

TABLE H5.2 Median Barrier Systems Characteristics Summary

Barrier System	Post Type	Category	NCHRP Report 350 Test Level	Design Deflection (m)	Minimum System Length (m)
High Tension Cable System	Steel Post	Flexible	TL-4	Depends on post spacing and choice of system, refer to manufacturer's information (2.1 to 2.4)	Refer to manufacturer's information (varies up to 35 m)
Weak Post Box Beam	Steel Post	Semi-Rigid	TL-3	1.5	100
Strong Post W-Beam	Plastic Post	Semi-Rigid	TL-3	1.5	50
	Wood or Steel Post	Semi-Rigid	TL-3	0.9	50
Standard Thrie Beam	Steel Post	Semi-Rigid	TL-3	0.6	50
Modified Thrie Beam	Steel Post	Semi-Rigid	TL-4	0.9	50
Precast Concrete Barrier – F-Shape or other approved shape (Temporary installation or special purpose permanent)	N/A	Rigid (must use crash tested joint between units and embedded by 50 mm)	TL-3	0.075 to 1.8	45
Cast-in-place or Extruded Single Slope or F-Shape Concrete Barrier Min. 810 mm High	N/A	Rigid	TL-4	0.0	30
Cast-in-place or Extruded Single Slope or F-Shape Concrete Barrier Min. 1070 mm High	N/A	Rigid	TL-5	0.0	30

Drawings for the median barrier systems, including transition information, are provided in **Appendix B** of this guide.

Consult the recommended products list to confirm that the selected end treatments may be used in Alberta. The recommended products list may be accessed on the INFTRA website.

If the median width is wider than the required Desirable Clear Zone such that the back of barrier system can be located outside of the Desirable Clear Zone, then other roadside barriers such as the Alberta Weak Post W-Beam, Strong Post W-Beam and Modified Thrie Beam may be used as a median barrier.

The Modified Thrie Beam barrier system may also be used as a median barrier for a short segment on overland flow routes or flood plains instead of a concrete barrier to provide flood relief during a major storm event. Additional discussion of this allowance is provided in **Section H4.7**.

New Jersey Concrete Barrier (TL-4) may only be used when connecting to or replacing a small segment of existing New Jersey Concrete Barrier.

Precast concrete barriers may be considered for permanent installations if the barriers need to be moved in the near future, such as when additional construction is anticipated within the next few years or when median crossovers or lane shifts in the median are required during construction. In this situation it would be more cost-effective to provide precast concrete barriers. The precast concrete barriers should be

embedded 50 mm into the pavement to ensure minimum design deflection.

Precast concrete barriers are considered TL-3 systems.

H5.4 Placement Considerations

Most barriers are designed for and tested on level terrain. Typically this installation would be located at the edge of the shoulder.

As a vehicle leaves the driving lane and crosses the shoulder and the embankment, the bumper height of the vehicle deviates from the standard height due to compression and expansion of the vehicle suspension system.

If the barrier cannot be placed at the edge of shoulder and the approach crossfall to the barrier cannot be maintained at 10:1 or flatter, then the barrier should be placed far enough back such that the errant vehicle will not go over the barrier, as a minimum.

Figure H5.1 illustrates the oscillation of the vehicle using the bumper height of the vehicle.

Table H5.3 provides the minimum distance for various sideslope ratios, as measured from the slope break point, to minimize the potential for errant vehicles to go over the barrier. The minimum distance as identified in the table is based on the encroachment angle of 25° with an approach speed of 100 km/h.

FIGURE H5.1 Typical Vehicular Oscillation on Embankment

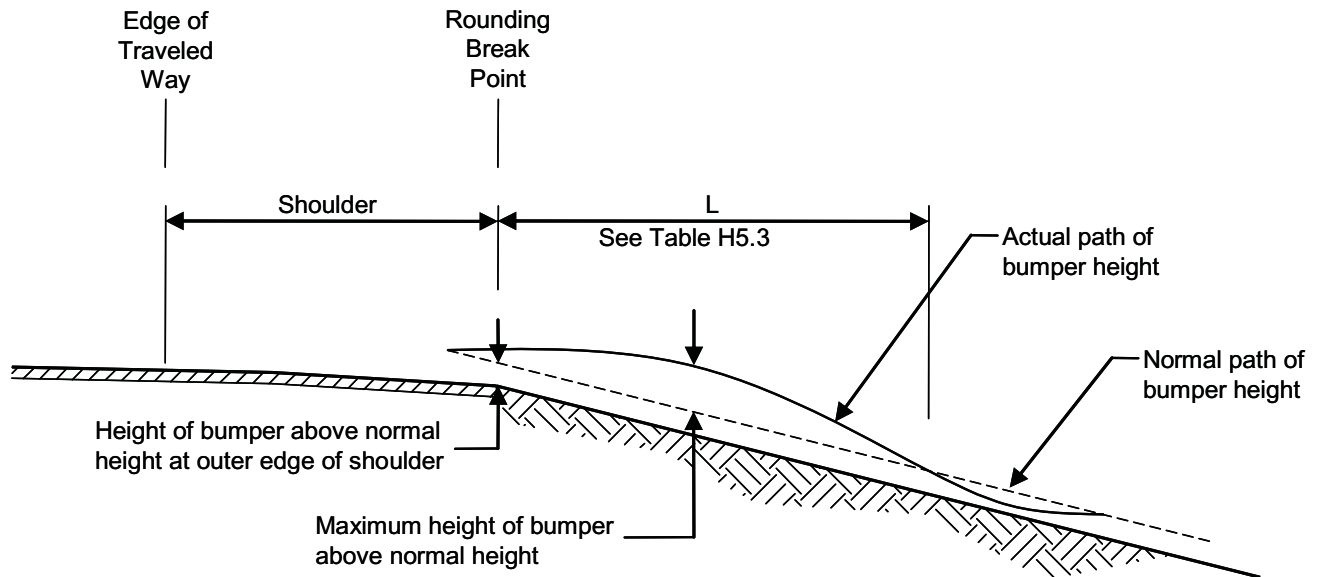

TABLE H5.3 Minimum Distance (L) for Barrier Placement

Sideslope	Minimum Distance L (m)
6 to 1	6.1
4 to 1	7.7
3 to 1	9.2
2 to 1	9.2

* Based on encroachment angle of 25° and approach speed of 100 km/h.

Other considerations may also influence the location and installation height of the barrier system. These include:

- Shy Line Offset
- Flare Rate
- Future Paving Requirements
- Zone of Intrusion
- Attachment to Barriers
- Stopping Sight Distance at Interchange Ramps.

H5.4.1 Shy Line Offset

The shy line offset is defined as the transverse distance measured from the edge of the driving lane to the inside face of the barrier system.

A suggested minimum shy line offset is provided as a guide for designers for barrier installation. Greater installation offsets are desirable, provided that this can be achieved at a reasonable cost and that the vehicle trajectory will still allow the barrier system to operate as designed.

For a **rural environment**, the suggested minimum shy line offset is:

- On all new structures, barrier installations or other features that may be considered as longitudinal hazards, the shy line offset should not be less than 1 m. For example, the width of new bridges on two lane roads should not be less than 9 m (clear roadway width). An exception to the 9 m minimum clear roadway would be on new bridge structures for SLC girders on specific low volume roadways. For further details, refer to Bridge Best Practice Guidelines, Minimum Bridge Widths for SLC Girder Structures on the Department webpage.
- The suggested minimum shy line offset should match or exceed the desirable shoulder width on the roadway for the service life of the infrastructure element

being designed. For example, for a new bridge the projected traffic volume for the next 50 years is of interest. It is normal practice on new bridge design to provide sufficient width such that widening would not be required in the 25 to 30 year range. For roadside guardrails mounted on wooden posts where the service life is normally 20 years or less, the width of the roadway during the shorter term is normally used.

- For lower volume divided highways (less than two-way 20,000 AADT) the suggested minimum shy line offset on the left hand side of the travel lanes is the standard left hand shoulder width for the design designation (2 m for four lanes, 2.5 m for six lanes, and 3 m for eight lanes).
- For higher traffic volumes (greater than 9000 AADT on an undivided highway or greater than 20,000 AADT on a divided highway) with design speed greater than 100 km/h, consider increasing the shy line offset above the desirable roadway shoulder. The suggested minimum is 3.0 m for bridges (associated cost increase to be considered) and 3.5 m for roadside barriers in isolation from bridges.
- Roadside barriers should normally be located no further than 4 m from the edge of the travel lane, since the chances of an errant vehicle hitting the barrier at a more obtuse angle increases with the offset. An exception to this rule is at the end of the barriers (flaring area) where the offset may be increased to more than 4 m.

These values are sometimes less than those recommended by TAC for the same speed. This is due to the use of high design speeds over a large component of the rural low-traffic-volume network in Alberta.

For economic considerations, some of these roadways may have a shoulder width of 1 m or

0.5 m with a design speed of 110 km/h. It is difficult to justify a large shy line offset when the shoulder is narrow and the traffic volume is low.

For **urban projects** including projects in urban fringe areas, such as the Calgary and Edmonton Ring Roads, INFTRA follows TAC's Suggested Shy Line Offset Values as shown in Table 3.1.6.4 of the *TAC 1999 Geometric Design Guide for Canadian Roads*. The offsets are to be measured from the edge of lane using the actual lane width provided on the subject road. In some cases this lane width may exceed 3.7 m where it has been developed to allow for bicyclists as well as motor vehicles.

H5.4.2 Flare Rate

Barrier systems are sometimes flared for a number of reasons:

- to place the end treatment further from the roadway
- to reduce driver reaction to the introduction of a barrier
- to transition the barrier alignment so that it can be attached to another fixed object, such as a bridge parapet
- to reduce the total length of barrier needed.

As the flare rate for the barrier systems increases, the severity of the collision with the flared segment also increases. In addition, the likelihood of that vehicle being redirected into or across the roadway following an impact also increases. As a result, the flare rate of the barrier system should be considered to minimize the potential for collision severity increase, as well as to minimize the potential to redirect a vehicle into or across the roadway following an impact.

Table H5.4 provides the minimum flare rate for High Tension Cable Barrier, Alberta Weak Post W-Beam, Strong Post W-Beam, Modified Thrie Beam, Box Beam, as well as Concrete Barriers, based on various design speeds.

TABLE H5.4 Minimum Flare Rate for Various Barrier Systems

Design Speed (km/h)	Flare Rate for Barrier inside Shy Line	Flare Rate for Barrier beyond Shy Line	
		Concrete Barrier	All Other Barrier Systems
50	13:1	8:1	7:1
60	16:1	10:1	8:1
70	18:1	12:1	10:1
80	21:1	14:1	11:1
90	24:1	16:1	12:1
100	26:1	18:1	14:1
110	30:1	20:1	15:1

H5.4.3 Future Paving Requirements

Consideration for Future Overlay Requirements

In 1999, INFTRA adopted a strategy to address the problem of narrow pavements. The strategy was intended to reduce the need to grade-widen paved roads through the use of forward thinking design concepts. A policy was subsequently developed to address the roadway width problem comprehensively in the three distinct phases of a roadway's life: new construction, rehabilitation, and widening.

Under the adopted policy, the grade and base course for all new construction or widening projects are to be built wider to accommodate two future 80 mm overlays.

A series of standard cross sections for various designations of highway have been produced and are included in the INFTRA standard drawings to identify these future paving requirements.

W-Beam Installation on Stage-Construction

Where a barrier is required on stage-construction projects, in which the first stage paving is to be constructed in anticipation that final paving will be delayed for between two and 10 years, an alternative installation method (as shown in **Figure H5.2**) may be used. The advantage of using this installation method is that it may avoid removing and reinstalling barriers at the time of final paving.

**FIGURE H5.2 Installation of Barrier on First Stage Paving Projects
(that are proposed to be final paved in less than 10 years)**

Excerpt from Standard Drawing TEB 3.56A.
Refer to TEB Standard Drawing for current version

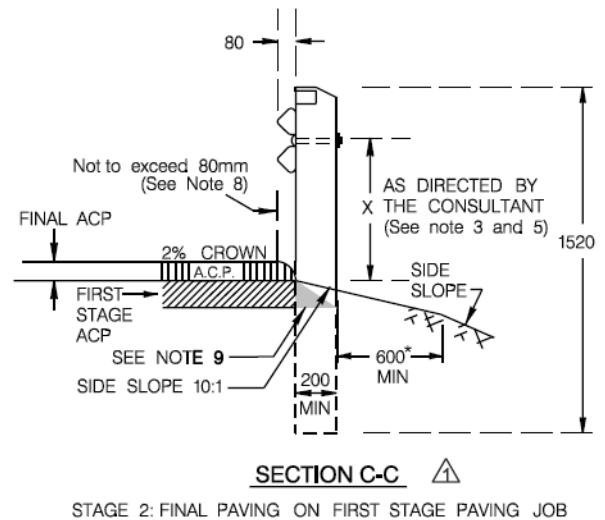
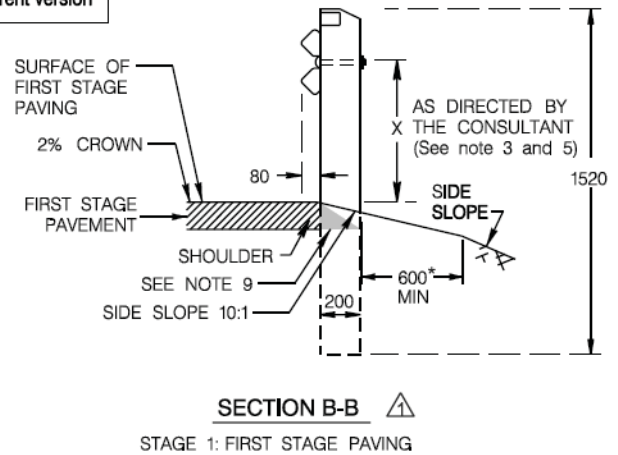
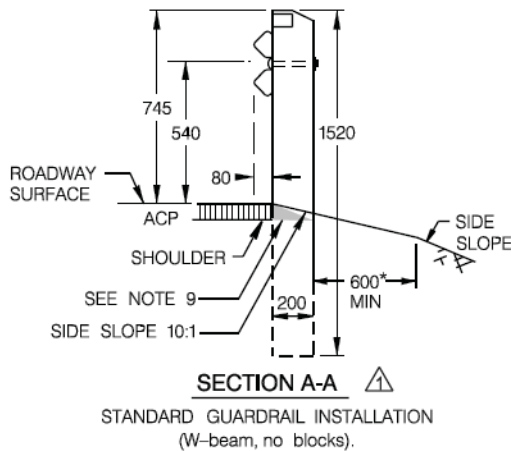

NOTES: ⚠

- Sections B-B, C-C and the Plan View show the special installation of guardrail that is suggested on projects where final paving is anticipated within 10 years.
- The standard height of guardrail from the road surface to the centre bolt is 540mm (Section A-A). The acceptable design range for height of guardrail installation is from 465mm to 615mm i.e. ± 75 mm
- The guardrail elevation 'x' is to be set by the consultant. An elevation between 540mm and 615mm is normally chosen for First Stage Paving projects. The elevation may be selected based on an estimate of the Final Pavement thickness. Where the final pavement thickness is not known, the highest permissible elevation should be considered.
- The acceptable tolerance for height of guardrail at time of construction or maintenance is shown in the applicable specification.
- By installing guardrail at the highest permissible elevation (Section B-B), the final pavement can be placed without the guardrail being removed or adjusted (Section C-C).
- All dimensions are in millimetres unless otherwise noted.
- Drawing is not to scale.
- Pavement drop-off line must not be more than 80mm from the guardrail post line. This is to prevent snagging.
- Installation of guardrail system normally requires post to be installed through ACP and GBC layers.

* The 600mm dimension may be exceeded if required by the consultant based on barrier type, hazard severity, embankment characteristics, etc.

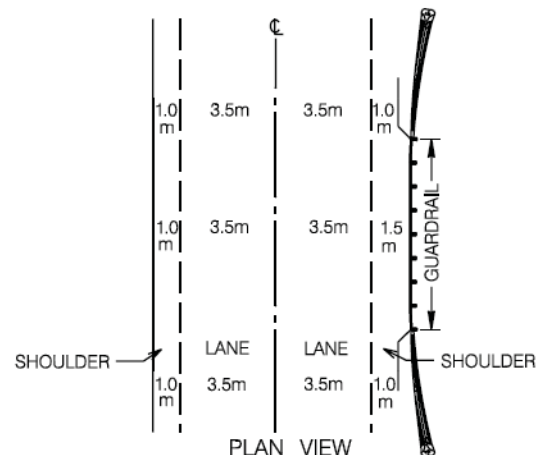

EXAMPLE SHOWING GUARDRAIL INSTALLATION
ON A TYPICAL RAU-209 ROADWAY AT STAGE 2

H5.4.4 Zone of Intrusion

The Zone of Intrusion is defined as the area above and beyond the face of a rigid barrier system in which components of commercial vehicles, pickup trucks or SUVs may enter during a crash with the system.

Because of the higher centre of gravity in commercial vehicles, a low rigid barrier may result in a partial overtopping of the rigid barrier during a crash.

For this reason, the Zone of Intrusion may affect the selection of a barrier system and placement of signs and poles behind the barrier.

As a result, the Zone of Intrusion should be considered for highways with high commercial vehicle traffic with a rigid barrier, and/or a barrier at a bridge structure. To be considered high in commercial vehicle traffic, a designer should examine the typical number of commercial vehicles per day rather than the percentage of commercial vehicles in the traffic stream.

Ideally, all hazards, including signs and poles with non-breakaway bases, should be placed outside of the Zone of Intrusion. Alternatively, the barrier height should be increased (refer to **Table H5.5**).

If the hazard cannot be relocated to outside of the Zone of Intrusion and a yielding or breakaway design is not possible, such as for high mast poles in a narrow median, then the hazard may be located within the Zone of Intrusion.

A 2003 study by the Midwest Roadside Safety Facility (*Report TRP-03-98-03*) identified the potential intrusion for various combinations of a rigid barrier (TL-2 to TL-4) with and without a curb at bridge structures.

Figure H5.3 illustrates the Zone of Intrusion requirements for various longitudinal traffic barrier systems used in Alberta.

The Zone of Intrusion for rigid barriers at TL-2 (test speed at 70 km/h) and TL-3 (test speed at 100 km/h) is based on pick-up trucks and SUVs. The Zone of Intrusion for rigid barriers, including semi-rigid TL-4 thrie beam barrier (test speed at 100 km/h) is based on cargo box rotation of delivery trucks.

The TL-4 barrier excludes the value for the New Jersey (NJ) shape barrier. The New Jersey shape barrier Zone of Intrusion value is significantly higher than the other TL-4 barrier systems.

Additional research is underway under the NCHRP program to determine the Zone of Intrusion for other types of barrier systems and may be incorporated into this document for use in the future.

Using this Zone of Intrusion information, a strategy was developed for use on Alberta highways. **Table H5.5** provides this strategy and obstacle setback requirements, and **Figure H5.4** illustrates the obstacle setback requirements.

FIGURE H5.3 Zone of Intrusion for TL-2, TL-3 and TL-4 Barriers

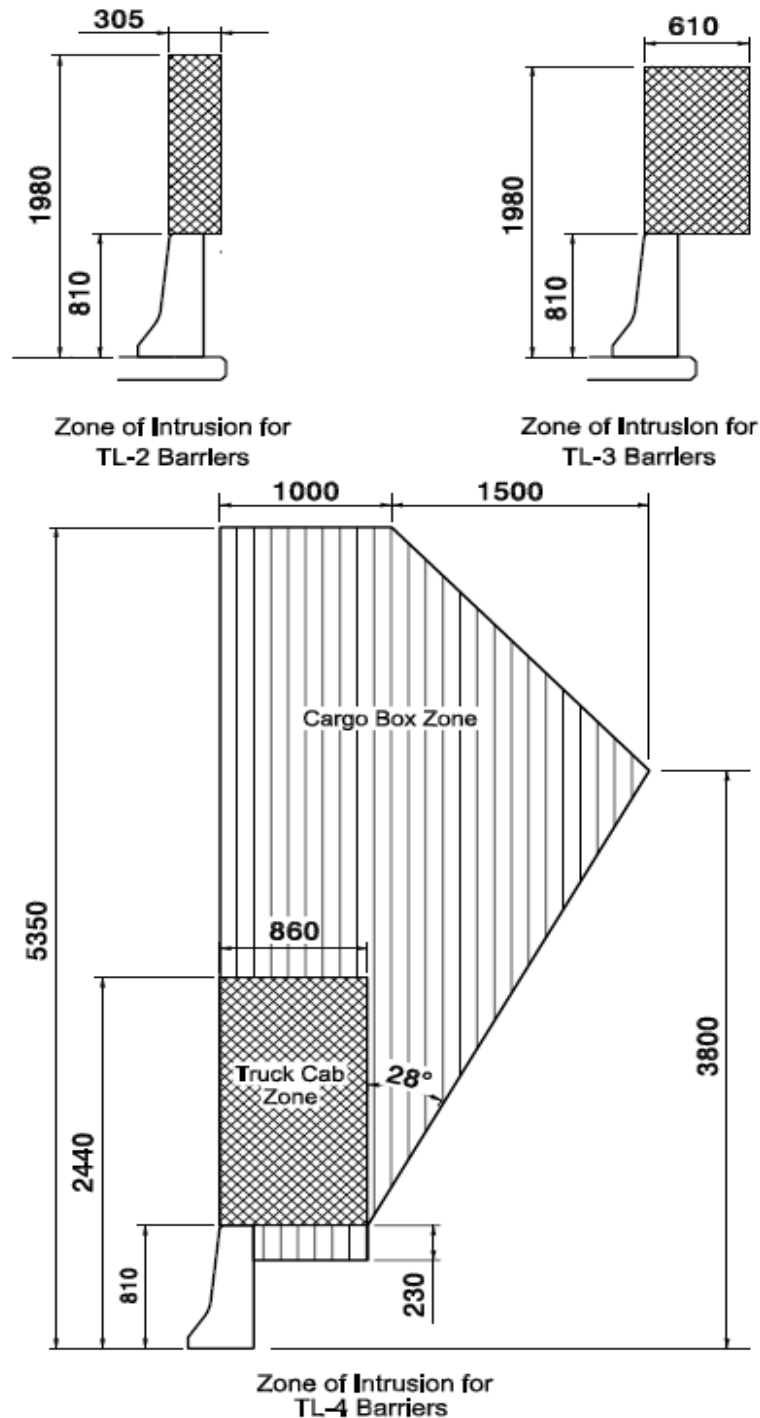

Note:

1. The zones of intrusion are based on crash test data from barriers of various shapes but rationalized for design purposes.
2. The New Jersey shape barrier Zone of Intrusion value (not shown here) is significantly higher than the values provided.
3. Refer to **Table H1.1** for Test Conditions for Longitudinal Barriers.
4. All dimensions are in millimetres.

TABLE H5.5 Obstacle Setback or Treatment for Zone of Intrusion Considerations

Features	Design Speed (km/h)	Applicable Roadway Barrier Standard	Obstacle Setback or Treatment
Bridge piers, abutment corners, overhead sign bridge columns, and high mast lighting	< 80	TL-2	<ul style="list-style-type: none"> 305 mm minimum behind top traffic face edge of rigid barriers, or the deflection allowance behind flexible barriers, whichever is greater.
		TL-3/TL-4	<ul style="list-style-type: none"> 610 mm minimum behind top traffic face edge of rigid barriers, or the deflection allowance behind flexible barriers, whichever is greater.
	≥ 80	TL-3	<ul style="list-style-type: none"> 610 mm minimum behind top traffic face edge of rigid barrier, or the deflection allowance behind flexible barriers, whichever is greater.
		TL-4	<ul style="list-style-type: none"> 3000 mm minimum behind top traffic face edge of rigid or Modified Thrie Beam barriers, OR 610 mm minimum behind top edge of barrier if the rigid barrier around obstacle is up-graded to a vertical face TL-5 barrier with minimum height of 1370 mm.
Structural support for bridge superstructure within the Clear Zone	< 80	N/A	<ul style="list-style-type: none"> Structural support to be designed for an equivalent static vehicle collision force of 1400 kN, at 10 degrees to the direction of travel, and at a distance of 1200 mm above ground (Reference CSA S6-06).
Structural support for bridge superstructure within 10 m from edge of ultimate pavement	≥ 80	N/A	<ul style="list-style-type: none"> Structural support to be designed for an equivalent static vehicle collision force of 1800 kN, assumed to act in any direction in a horizontal plane, at a distance of 1200 mm above ground (Reference AASHTO LRFD Bridge Design Specifications 2007).

TABLE H5.5 Obstacle Setback or Treatment for Zone of Intrusion Considerations

Features	Design Speed (km/h)	Applicable Roadway Barrier Standard	Obstacle Setback or Treatment
Less significant hazards such as conventional light poles, and small signs	< 80	All	<ul style="list-style-type: none"> • Engineering judgement should be used when designing barrier systems to provide a balance between the risk and cost. • Where clearance of less than 305 mm is used, these should be treated as design exceptions and documentation for the rationale to support the design choices should be provided.
		TL-3	<ul style="list-style-type: none"> • 610 mm minimum behind top traffic face edge of rigid barriers, or the deflection allowance behind flexible barriers, whichever is greater.
	≥ 80	TL-4	<ul style="list-style-type: none"> • Higher bridge rail heights (similar to bridge rail standard drawings S-1700-06 or S-1702-06) should be considered with a set-back of 610 mm behind the barrier. • Engineering judgement should be used when designing barrier systems to provide a balance between the risk and cost.

FIGURE H5.4 Obstacle Setback Requirements

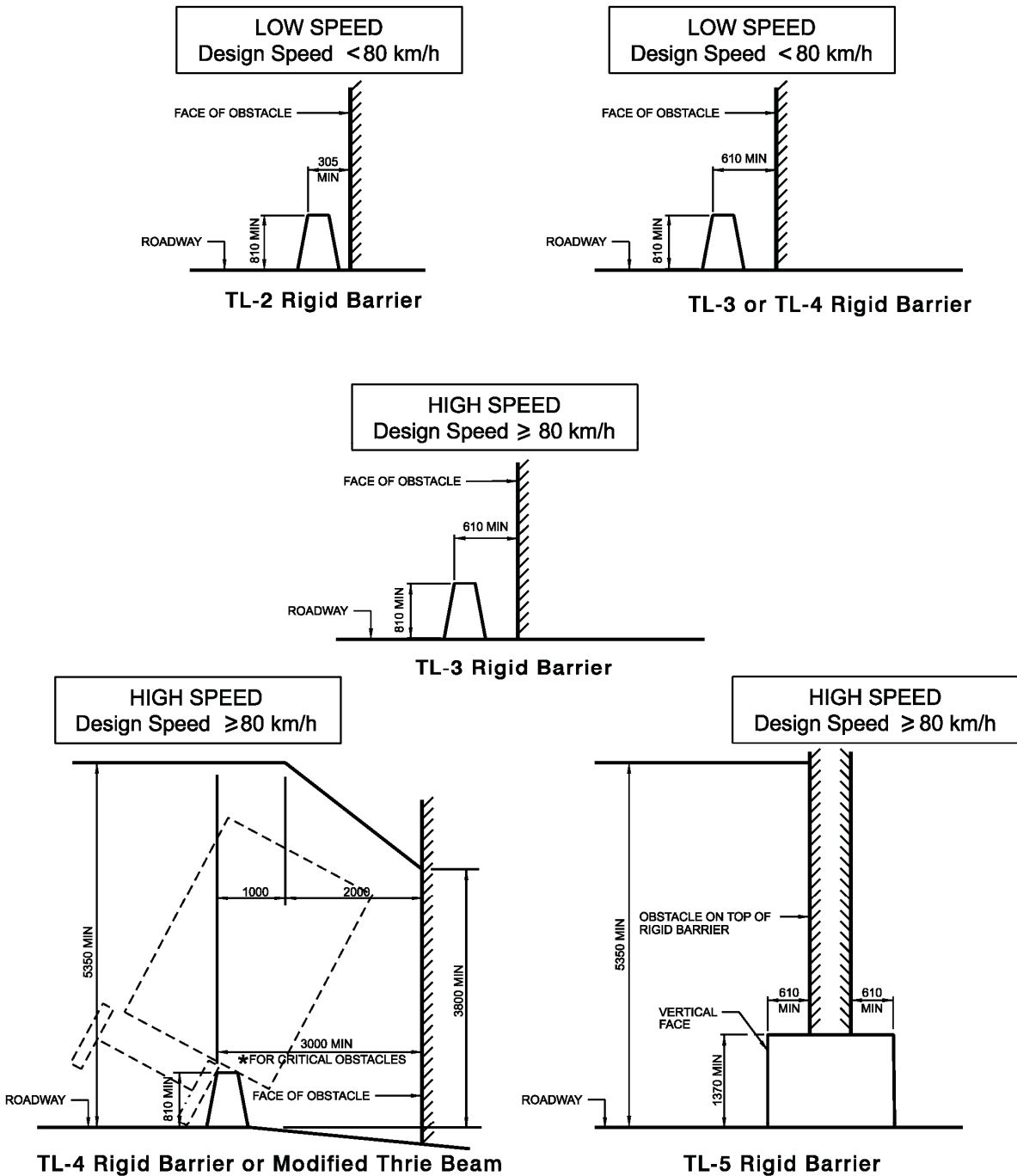

All dimensions are in millimetres

Notes:

- * Critical obstacles are defined as bridge piers, abutment corners, overhead sign support columns and high mast lighting poles.
- These diagrams are to be used in conjunction with Table H.5.5 Obstacle Setback or Treatment for Zone of Intrusion Considerations.
- Refer to Table H.5.5 for conditions pertaining to less significant hazards.

H5.4.5 Attachments to Barrier Systems

For a rigid discrete (single) attachment, ideally, the attachment should be placed outside of the Zone of Intrusion. If the attachment must be placed closer to the roadway to operate properly (for example light poles), or if the cost to place the attachment outside of the Zone of Intrusion outweighs the benefit, then the attachment may be placed within the Zone of Intrusion.

For a breakaway discrete attachment, the attachment should be placed outside of the Zone of Intrusion 900 mm from the front of the barrier system, and in a location where debris from the breakaway attachment will not become a hazard to traffic or pedestrians.

For a yielding discrete attachment, the attachment may be placed within the Zone of Intrusion. The location of attachment must consider the potential of debris hazard to traffic and pedestrians.

For a continuous attachment, the posts should be mounted a minimum of 178 mm behind the barrier to reduce potential snagging, whenever possible. The location of the attachment must consider the potential of debris hazard to traffic and pedestrians.

Refer to the 2003 Report TRP-03-98-03 - *"Guidelines for Attachments to Bridge Rail and Median Barriers"* for additional information.

H5.4.6 Stopping Sight Distance on Directional Interchange Ramps

Where directional ramps are built going over or under other roadways, there is normally an obstruction to the horizontal line of sight by either the barrier system on the approach or the bridge pier/barrier system.

The minimum sight distance required on any roadway is the stopping sight distance.

When a barrier system is required on interchange ramps, particularly at the ramp or side road intersection, consider increasing the shy line offset to accommodate the stopping sight distance requirements.

In most cases, directional ramps are curved to the left (in the direction of travel). As a result, the left barrier offset generally needs to be increased to provide the necessary stopping sight distance for the design speed.

Where a very wide offset is needed and there is a possibility of drivers mistaking this offset as an extra lane, consider additional guidance devices such as pavement markings (including durable markings), flexible delineators, and/or rumble strips. A two lane ramp (instead of a one lane) could also be considered.

H5.5 Barrier System Characteristics

H5.5.1 Alberta Weak Post W-Beam



Alberta Weak Post W-Beam Barrier is a non-proprietary, flexible barrier system designed to contain and redirect vehicles.

Two types of the Alberta Weak Post W-Beam Barrier system are available:

- wood post design
- plastic post design.

The wood post design uses 152 mm x 203 mm x 1520 mm wood posts. Longer posts may be used as required.

The plastic post is a proprietary product of Amity Plastics Limited of Clyde, Alberta, and uses recycled plastic materials. The length of a plastic post is also 1520 mm.

Appendix B1 provides the standard drawings for the Alberta Weak Post W-Beam Barrier System.

Table H5.6 summarizes the characteristics of the Alberta Weak Post W-Beam Barrier.

TABLE H5.6.
Alberta Weak Post W-Beam Characteristics

Characteristics	
Design Deflection	2.5 m
Installation height (centre of rail)	540 mm
Design tolerance of installation height	±75 mm
Minimum length	22.86 m (≤ 70 km/h) ¹ 45.72 m (≥ 80 km/h) ¹
Placement	Flat shoulders or slopes 10:1 or flatter
Combination with Curb	See restrictions in Section H4.3

¹ Minimum length for weak post w-beam does not include length of end treatments. The corresponding speeds are based on design speed.

Restrictions

Alberta Weak Post W-Beam Barrier should not be installed under the following conditions:

- as a median barrier system unless the median is wide enough so that vehicles impacting the back of the system are not a consideration
- attached directly to a rigid object, whether it is another barrier system or a hazard.

In addition to the general restrictions, plastic posts should not be used:

- in a transition area between a roadway barrier system and bridge rail system
- as part of a proprietary end treatment such as CAT-350.

For restriction when installed in conjunction with curb, refer to **Section H4.3**.

Alberta Weak Post W-Beam Barrier may be used in the median if the width is wider than the required Desirable Clear Zone such that the back of the barrier system will be outside of the Desirable Clear Zone for the opposite direction.

End Treatments

Both *NCHRP Report 350*-approved TL-3 end treatments and non-*NCHRP Report 350*-approved end treatments are currently used in Alberta.

The non-*NCHRP Report 350*-approved end treatments are:

- Turn Down
- Wing End.

The Turn Down end treatment is preferred when a TL-3 end treatment is not required.

Wing End treatments may be used for the downstream of systems on divided highways where the end of the system is beyond the Desirable Clear Zone distance for opposing traffic.

All TL-3 end treatments identified are designed to connect with Strong Post W-Beam barrier system. A transition from the Alberta Weak Post W-Beam to the Strong Post W-Beam is required prior to the installation of the TL-3 end treatment.

NCHRP Report 350 approved TL-3 end treatments include:

- Flared Energy Absorbing Terminal (FLEAT)
- ET-Plus
- FLEAT-MT (for median end treatment)
- CAT-350.

When TL-3 end treatments are required, the FLEAT and FLEAT-MT end treatments are the preferred treatments for roadside and median applications respectively.

Additional information on each of the end treatments is provided in **Section H6**.

Transitions

Transitioning from the Alberta Weak Post W-Beam Barrier to semi-rigid barrier systems such as the Strong Post W-Beam Barrier or

Modified Thrie Beam Barrier are easily achieved over a relatively short barrier transition length. The transition to Strong Post W-Beam is made by physically connecting the two systems at a single post at a guardrail splice point and adding one additional weak post as shown in standard drawing RDG-B1.9.

When transitioning the Alberta Weak Post W-Beam Barrier to Modified Thrie Beam Barrier, an intermediate transition to Strong Post W-Beam Barrier is required to ensure a gradual transition in stiffness. The length of Strong Post W-Beam Barrier should be no less than 3810 mm (i.e. two post spacings at 1905 mm on centre). This intermediate transition is illustrated on standard drawing RDG-B1.9 in **Appendix B1**.

The transition between Strong Post W-Beam Barrier and Modified Thrie Beam Barrier is illustrated on standard drawing RDG-B5.5 in **Appendix B5**.

Direct connections of an Alberta Weak Post W-Beam Barrier system to a rigid system, structure, or hazard are not permitted on new installations. Significant differences in the deflection characteristics of the two elements could cause pocketing or snagging, and could result in severe collisions.

When connecting the Alberta Weak Post W-Beam Barrier system to a rigid barrier system such as a concrete barrier, a series of intermediate transitions are required. First, the Alberta Weak Post W-Beam Barrier must be transitioned to Modified Thrie Beam Barrier by first introducing a section of W-Beam Strong Post Barrier as described above. The final connection to concrete barrier is made by using two layers of 2.7 mm thick Thrie Beam panels as well as reducing the Thrie Beam Barrier post spacing and mechanically anchoring to the concrete barrier using a Thrie Beam terminal connector. This is illustrated on standard drawing RDG-B6.15 in **Appendix B6**.

Transition details for a median barrier application are illustrated on standard drawing RDG-B6.12 in **Appendix B6**.

When the rigid barrier system consists of Precast Concrete Safety Shape Barriers such as F-Shape Barriers or New Jersey Barriers, the orientation of the Thrie Beam panels must be kept in the vertical plane. Twisting the Thrie Beam panels to mount flush on the inclined face of a safety shape barrier is not permitted.

When the flow of traffic is bidirectional, the Thrie Beam Barrier must be connected to a transition section of concrete barrier that meets the following criteria:

- The end of the concrete barrier is transitioned to a vertical profile.
- A 460 mm long x 110 mm deep recessed wedge is provided at the end of the transition to mitigate wheel snagging (refer to standard drawing RDG-B6.13 in **Appendix B6** for details).
- The horizontal flare along the top of the barrier is maintained at 20(min):1.

When the flow of traffic is unidirectional, a transition in the safety shape concrete barrier to a vertical face is not required, however, the Thrie Beam panels must still be orientated in the vertical plane.

Regardless of whether the flow of traffic is unidirectional or bidirectional, the Thrie Beam Barrier must be mechanically anchored to the Safety Shape Precast Concrete Barrier using a fully anchored Thrie Beam terminal connector.

The main principle of the transition is to provide a gradual increase in rigidity, allowing an impacting vehicle to transition from one system to the other without pocketing or snagging.

For an existing Alberta Weak Post W-Beam Barrier system currently connected directly to a rigid structure, the transition should be

upgraded when the next bridge rehabilitation takes place.

Maintenance Requirements

Typically the barrier should be inspected at least every two years to confirm that the system is in proper working order.

Maintenance inspection activities would typically include checking the following:

- barrier height
- vertical plumb (layback) of post
- deformation of beam element
- beam and post condition.

H5.5.2 High Tension Cable System



The High Tension Cable system is currently under review as an Introductory System. Consult INFTRA's Technical Standards Branch prior to using the High Tension Cable system as the appropriate barrier system.

The following section presents one of the High Tension Cable Barrier systems currently approved by FHWA as a TL-4 cable system.

At the time of writing, three TL-4 cable systems were approved by FHWA, namely Brifen, CASS, and Gibraltar. It is generally a good practice in a construction tender to call for a barrier system of a particular type (for example, a High Tension Cable Barrier System) with a particular test level (TL-4) rather than specifying a proprietary system.

Appendix B2 provides website links for approved High Tension Cable Barrier Systems.

Table H5.7 summarizes the characteristics of the High Tension Cable Barriers.

TABLE H5.7
High Tension Cable Barrier Characteristics

Characteristics	
Design Deflection	2.1 m to 2.4 m
Installation height (top cable)	Refer to manufacturer's information
Design tolerance of installation height	Refer to manufacturer's information
Minimum length	varies up to 35 m
Placement	Flat shoulders or slopes 6:1 or flatter
Combination with Curb	See restrictions in Section H4.3

Restrictions

The High Tension Cable System should not be attached directly to a rigid object, whether it is another barrier system or a hazard.

For restriction when installed in conjunction with curb, refer to **Section H4.3**.

Consult the manufacturers to determine other restrictions for the particular High Tension Cable System.

End Treatments

Consult the manufacturers to determine the appropriate end treatment for the particular High Tension Cable System.

Transitions

Direct connection of the High Tension Cable system to a rigid barrier system, existing structure, or hazard is generally not permitted. Significant differences in the deflection characteristics of the two elements could cause pocketing or snagging, and potentially result in serious injuries.

The transition design establishes sufficient overlap between the two systems so that the

impacting vehicle cannot penetrate one system without engaging the other installation rather than physically connecting the systems to one another.

Consult the manufacturers to determine the appropriate transition treatment for the particular High Tension Cable System.

Maintenance Requirements

Typically the barrier should be inspected at least every two years to confirm the system is in good working order.

After impacts, the High Tension Cable System may remain in tension depending on the severity of the collision and as a result, the system can still provide some protection to motorists unlike standard conventional cable barrier systems which typically are not operated at high tension.

Consult the manufacturers to determine the maintenance requirements for the particular High Tension Cable System.

H5.5.3 Weak Post Box Beam



The Weak Post Box Beam Barrier is a non-proprietary, semi-rigid barrier system designed to contain and redirect vehicles.

The Weak Post Box Beam Barrier is generally not used in Alberta except in special circumstances where the designer has provided site-specific justification.

The Weak Post Box Beam Barrier system uses S75 x 8 steel posts with soil resistance plates. The required length of the steel posts is 1635 mm.

Appendix B3 provides the standard drawings for Weak Post Box Beam Barrier System.

Table H5.8 summarizes the characteristics of the Weak Post Box Beam Barrier.

TABLE H5. 8
Weak Post Box Beam Characteristics

Characteristics	
Design Deflection	1.5 m
Installation height (top of rail)	735 mm
Design tolerance of installation height	±25 mm
Minimum length ¹	100 m
Placement	Flat shoulders or slopes 10:1 or flatter
Combination with Curb	See restrictions in Section H4.3

1. Does not include length of end treatment.

Restrictions

With the exception of the curb restrictions as outlined in **Section H4.3**, there are no restrictions for the Weak Post Box Beam Barriers.

End Treatments

Both *NCHRP Report 350*-approved TL-3 end treatments and non-*NCHRP Report 350*-approved end treatments are currently used in Alberta:

- Turn Down End Treatment (non-*NCHRP Report 350*-approved end treatment) if AADT < 10,000 vpd
- Bursting Energy Absorbing Terminal (TL-3 end treatment).

Additional information on each end treatment is provided in **Section H6**.

Transitions

The Weak Post Box Beam Barrier may be attached to a bridge railing using a transition. Standard drawings are available on INFTRA's website. This is also shown on standard drawing TEB 3.41.

In any transition installation, the systems are generally not physically connected to one another due to the different configuration of the Weak Post Box Beam to other systems. The main principle in this kind of transition is to establish sufficient overlap between the two systems so that the impacting vehicle cannot penetrate one system without engaging the other.

Maintenance Requirements

Typically the barrier should be inspected every two years to confirm the system is in working order. Maintenance inspections activities would typically include checking the following:

- barrier height
- vertical plumb (layback) of post
- deformation of beam element
- beam and post condition.

H5.5.4 Strong Post W-Beam



The Strong Post W-Beam Barrier is a non-proprietary, semi-rigid barrier system designed to contain and redirect vehicles.

The following three types of the Strong Post W-Beam Barrier systems are available:

- steel post design
- wood post design
- plastic post design.

The steel post design requires W150 x 14 x 1830 mm steel posts without soil resistance plate.

The wood post design uses 152 mm x 203 mm x 1830 mm wood posts.

The plastic post is a proprietary product of Amity Plastics Limited of Clyde, Alberta, and uses recycled plastic materials. The length of a plastic post is also 1830 mm.

Appendix B1 provides the standard drawings for the Strong Post W-Beam Barrier System.

Table H5.9 summarizes the characteristics of the Strong Post W-Beam Barrier.

TABLE H5.9
Strong Post W-Beam Characteristics

Characteristics	
Design Deflection	
• Plastic Post	1.5 m
• Wood or Steel Post	0.9 m
Installation height (centre of rail)	550 mm
Design tolerance of installation height	±75 mm
Minimum length	50 m
Placement	Flat shoulders or slopes 10:1 or flatter
Combination with Curb	See restrictions in Section H4.3

Restrictions

Strong Post W-Beam Barrier with w-beam guardrail fastened on one side of the post only, should not be installed in the median unless the median width is wider than the required Desirable Clear Zone such that the back of barrier system will be outside of the Desirable Clear Zone for the opposite direction.

Otherwise, placing spacer blocks and w-beam guardrail on both sides of the post may be used for median applications.

For restrictions when installed in conjunction with curb, refer to **Section H4.3**.

In addition to the general restrictions, plastic posts should not be used:

- in a transition area between a roadway barrier system and a bridge rail system
- as part of a proprietary end treatment such as CAT-350.

Plastic posts may be used in advance of the transition area between the roadway barrier system and bridge rail system but they need to be transitioned to a wood or steel post system prior to this area. Plastic posts are not allowed within the transition and connection to bridge ends.

Only wood or plastic spacers are acceptable with W-Beam barriers. Steel spacers should not be used.

End Treatments

Both *NCHRP Report 350*-approved TL-3 end treatments and non-*NCHRP Report 350*-approved end treatments are currently used in Alberta.

For non-*NCHRP Report 350*-approved end treatments, the following products are available:

- Turn Down
- Wing End.

The Turn Down end treatment is preferred when a TL-3 end treatment is not required.

Wing End treatments may be used for the downstream of systems on divided highways where the end of the system is beyond the Desirable Clear Zone distance for opposing traffic.

For *NCHRP Report 350*-approved TL-3 end treatments, the following products are available:

- Flared Energy Absorbing Terminal (FLEAT)
- ET-Plus
- FLEAT-MT (for median end treatment)
- CAT-350.

When a TL-3 end treatment is required, the FLEAT and FLEAT-MT end treatments are preferred for roadside and median applications respectively.

Additional information for each of the end treatments is provided in **Section H6**.

Transitions

Strong Post W-Beam Barrier may be connected to rigid barrier systems by first transitioning to a Modified Thrie Beam Barrier. The design must provide a smooth, progressively stiffened transition that will prevent vehicle snagging, pocketing or penetration. The transition section

should be of sufficient length to prevent significant changes in deflection within a short distance. No gaps or discontinuities are permitted between the approach barrier system and the rigid element.

Transitioning Strong Post W-Beam Barrier to Modified Thrie Beam Barrier is accomplished as shown on standard drawing RDG-B5.5 in **Appendix B5**.

For transitioning Strong Post W-Beam Barrier to a rigid barrier system such as a concrete barrier, an intermediate transition to Thrie Beam Barrier is required to ensure a gradual increase in barrier stiffness. For Cast-In-Place Single Slope Concrete Barrier, the intermediate transition is shown on standard drawing RDG-B6.15 in **Appendix B6**.

When the rigid barrier system consists of Precast Concrete Safety Shape Barriers such as F-Shape Barriers or New Jersey Barriers, the orientation of the Thrie Beam panels must be kept in the vertical plane. Twisting the Thrie Beam panels to mount flush on the inclined face of a safety shape barrier is not permitted.

When the flow of traffic is bidirectional, the Thrie Beam Barrier must be connected to a transition section of concrete barrier that meets the following criteria:

- The end of the concrete barrier is transitioned to a vertical profile.
- A 460 mm long x 110 mm deep recessed wedge is provided at the end of the transition to mitigate wheel snagging (refer to standard drawing RDG-B6.13 in **Appendix B6** for details).
- The horizontal flare along the top of the barrier is maintained at 20(min):1.

When the flow of traffic is unidirectional, a transition in the safety shape concrete barrier to a vertical face is not required however the Thrie

Beam panels must still be orientated in the vertical plane.

Regardless of whether the flow of traffic is unidirectional or bidirectional, the Thrie Beam Barrier must be mechanically anchored to the Safety Shape Precast Concrete Barrier using a fully anchored Thrie Beam terminal connector. This requirement is illustrated in the standard drawing RDG-B6.13 in **Appendix B6**.

The transition from a Strong Post W-Beam Barrier to a High Tension Cable Barrier requires overlapping of the two systems. This is because significant differences in the deflection characteristics of the two elements may cause vehicle pocketing or snagging, and potentially result in severe collisions. A crashworthy transition between Strong Post W-Beam Barrier and High Tension Cable Barrier is illustrated on Standard Plan C-3d (2 sheets) from the Washington Department of Transportation. These drawings are available on the Washington DOT website.

Road Systems Inc., a proprietary supplier of guardrail end treatments, has also developed a similar transition that has been crash tested to NCHRP TL-3. Details of this transition are available on their website.

In situations where Strong Post W-Beam Barrier is transitioned to Alberta Weak Post W-Beam Barrier, the connection is made as shown on standard drawing RDG-B1.9.

Maintenance Requirements

Typically the barrier should be inspected every two years to confirm the system is in working order.

Maintenance inspections activities would typically include checking the following:

- barrier height
- vertical plumb (layback) of post
- deformation of beam element
- beam and post condition.

H5.5.5 Modified Thrie Beam



Modified Thrie Beam Barrier is a non-proprietary, semi-rigid barrier system designed to contain and redirect vehicles.

The Modified Thrie Beam Barrier system is available only with steel post design. This design uses W150 x 13.5 x 2.06 m steel posts without soil resistance plates.

Appendix B5 provides the standard drawings for the Modified Thrie Beam Barrier System.

Table H5.10 summarizes the characteristics of the Modified Thrie Beam Barrier.

TABLE H5.10
Modified Thrie Beam Characteristics

Characteristics	
Design Deflection	600 mm (as TL-3 system) ¹ 900 mm (as TL-4 system)
Installation height (top of rail)	890 mm
Design tolerance of installation height	±50 mm
Minimum length	50 m
Placement	Flat shoulders or slopes 10:1 or flatter
Combination with Curb	See restrictions in Section H4.3

¹ Note: TL-3 is for standard thrie beam (mid-height of rail set 550 mm above pavement).

The design deflection of 0.9 m is based on the crash test using 9,100 kg and 14,500 kg school buses. The actual design deflection using an 8,000 kg single unit truck, as required under *NCHRP Report 350* for TL-4 testing, is expected to be less.

For design purposes, a design deflection of 0.9 m should be assumed unless proven otherwise by crash testing.

Restrictions

Typically, the Modified Thrie Beam Barrier (MTBB) with thrie beam guardrail fastened on one side of the post only, should not be installed in the median unless the median width is wider than the required Desirable Clear Zone such that the back of the barrier system will be outside of the Desirable Clear Zone for the opposite direction. Otherwise, placing spacer blocks and thrie beam guardrail on both sides of the post may be used for median applications. In addition, MTBB may also be used for a short segment for an overland flow route or flood plain instead of a concrete barrier to provide flood relief during a major storm event.

For restriction when installed in conjunction with curb, refer to **Section H4.3**.

End Treatments

Both *NCHRP Report 350*-approved TL-3 end treatments and non-*NCHRP Report 350*-approved end treatments are currently used in Alberta.

For non-*NCHRP Report 350*-approved application, the Wing End for leaving end only on divided highway may be used where the end of the system is beyond the Desirable Clear Zone distance for opposing traffic.

End treatments are not designed for direct connection to the Modified Thrie Beam Barrier system. Transition to a Strong Post W-Beam system prior to installation of end treatment is required. This is illustrated in standard drawing RDG-B5.5 in **Appendix B5**.

For *NCHRP Report 350*-approved TL-3 end treatments, the following products are available:

- Flared Energy Absorbing Terminal (FLEAT)
- ET-Plus
- FLEAT-MT (for median end treatment)
- CAT-350.

The FLEAT and FLEAT-MT end treatments are preferred for roadside and median applications, respectively.

Additional information on each of the end treatments is provided in **Section H6**.

Transitions

Modified Thrie Beam Barrier may connect directly to rigid barrier systems, as well as to structures such as concrete bridge barriers and to concrete parapets at the ends of vertical bar/horizontal rail type bridgerails. The design goal for this connection is to maintain a smooth, progressively stiffened transition that will prevent vehicle snagging, pocketing or penetration. This is accomplished by using two layers of 2.7 mm thick Thrie Beam panels as well as gradually reducing the Thrie Beam post spacing as the Thrie Beam Barrier approaches the rigid barrier system. The essence of this standard transition is captured in the bridge approach rail transition for the PL-2 Single Slope Concrete Bridge Barrier as shown on standard drawings S-1650-00 and S-1651-00.

The design must provide a gradual increase in stiffness from the standard section of the barrier to the rigid barrier system being connected. The transition section should also be of sufficient length to prevent significant changes in deflection within a short distance. No gaps or discontinuities are allowed between the approach barrier system and the rigid element.

When transitioning to a more flexible barrier system where the flow of traffic is unidirectional and the barrier falls within the Clear Zone, the

Modified Thrie Beam Barrier may be connected directly to the more flexible barrier system without a gradual transition in stiffness, provided that the more flexible barrier system is downstream of the Modified Thrie Beam Barrier. When the flow of traffic is bidirectional, a gradual transition in stiffness is required for the reasons noted previously. A description of the transition to Strong Post W-Beam Barrier or Alberta Weak Post W-Beam Barrier may be found under the “Transitions” subheading for these corresponding barriers presented earlier in **Section H5**.

Maintenance Requirements

Typically, the barrier should be inspected at least every two years to confirm the system is in working order.

Maintenance inspection activities would typically include checking the following:

- barrier height
- vertical plumb (layback) of post
- deformation of beam element
- beam and post condition.

H5.5.6 Cast-In-Place or Extruded Concrete Barrier



Cast-In-Place Concrete Barrier systems are rigid and designed to redirect vehicles. These are the least forgiving of all barrier systems and therefore often result in more severe crashes.

In general, three types of Concrete Barrier may be used:

- Extruded
- Cast-in-place
- Precast (generally only Single Slope or F-Shape, as discussed in **Section H5.5.7**, are available)

In general, where a concrete barrier system has been chosen, a cast-in-place or extruded system is preferred over a precast system due to aesthetics and better performance in crashes especially for larger vehicles.

Concrete Barriers may vary in shape and height. Barrier shapes include:

- Single Slope concrete barrier
- F-Shape concrete barrier
- Vertical wall concrete barrier
- New Jersey Shape concrete barrier.

These barrier systems are noted as follows:

TABLE H5.11
Test Level (TL) Rating of Cast-in-place or Extruded Concrete Barriers

Barrier Height	Barrier Type	Test Level (TL)
810 mm	Single Slope	TL-4
	Vertical Wall	TL-4
	F-Shape	TL-4
	New Jersey Shape	TL-4
1070 mm	Single Slope	TL-5
	Vertical Wall	TL-5

TABLE H5.12
Test Level (TL) Rating of Precast Concrete Barriers

Barrier Height	Barrier Type	Test Level (TL)
All	All	TL-3

The Single Slope concrete barrier is the preferred shape because of its compatibility with bridge barrier systems and the ability to accommodate future pavement overlays without adjusting the barrier, provided that the minimum effective barrier height is maintained.

F-Shape and New Jersey shape barriers should only be used to replace short segments or to tie into existing F-Shape and New Jersey barriers.

Embedding precast concrete barrier systems into the roadway surface may be done to improve barrier stability and reduce barrier deflection.

Appendix B6 provides the standard drawings for Cast-in-Place or Extruded Concrete Barrier System.

Table H5.13 summarizes the characteristics of Concrete Barriers.

TABLE H5.13
Cast-In-Place Concrete Barrier Characteristics

Characteristics	
Design Deflection	0 mm
Installation height (top of barrier)	810 mm or 1070 mm (Single Slope and Vertical Wall)
	810 mm (F-Shape and New Jersey)
Design tolerance of installation height	±25 mm
Minimum length	30 m
Placement	Flat shoulders or slopes 10:1 or flatter in front of and a minimum distance of 0.5 m behind the system to ensure system stability
Combination with Curb	See restrictions in Section H4.3

Restrictions

Concrete Barriers should not be installed under the following conditions:

- where potential flooding of the highway may occur

For restriction when installed in conjunction with curb, refer to **Section H4.3**.

End Treatments

For non-NCHRP Report 350-approved end treatments when posted speed is less than or equal to 60 km/h, the Flared and Tapered Down end treatment should be used. This treatment is illustrated in **Appendix B6**.

For NCHRP Report 350-approved TL-3 end treatment, the following products are available:

- TRACC
- CAT-350
- QuadGuard.

The TRACC and CAT-350 systems are the preferred end treatments for lower volume highways with AADT ≤ 50,000 vpd where system hits are less likely to occur.

The QuadGuard system is preferred for higher volume highways with AADT > 50,000 vpd.

Additional information on each of the end treatments is provided in **Section H6**.

Transitions

Concrete Barriers may only be transitioned directly to semi-rigid and other rigid barrier systems.

Maintenance Requirements

Concrete Barriers generally require minimal maintenance once the system is installed.

Inspection of the barrier system is not generally necessary unless significant spalling or cracking of the concrete has been identified that may compromise the integrity of the system.

H5.5.7 Precast Concrete Barrier



A Precast Concrete Barrier is a portable segmented barrier system used primarily during construction.

Single Slope and F-Shape Precast Concrete Barriers are the systems currently approved for use in Alberta.

Precast Concrete Barriers may be considered for permanent installations if a TL-3 barrier is acceptable and the barrier needs to be moved in the near future. It may be more cost effective to provide precast concrete barriers when additional construction is anticipated within the next few years or when median crossovers or lane shifts in the median are required during construction.

Precast Concrete Barrier as a permanent installation may be embedded 50 mm into the pavement to minimize design deflection.

Appendix B4 provides available standard drawings for the Precast Concrete Barrier System.

Table H5.14 summarizes the characteristics of Precast Concrete Barriers.

TABLE H5.14
Precast Concrete Barrier Characteristics

Characteristics	
Design Deflection	1.8 m (Unanchored) 75 mm to 900 mm (Anchored) *
Design Performance	TL-3
Installation height (top of barrier)	810 mm
Design tolerance of installation height	No restriction
Minimum length	45 m
Placement	Flat shoulders or slopes 10:1 or flatter
Combination with Curb	See restrictions in Section H4.3

* Design deflection for anchored systems depends on the method of anchoring. Refer to standard drawing CB6 4.2M 16 for design deflection values based on various anchoring methods.

Restrictions

Precast Concrete Barriers should not be installed under the following conditions:

- horizontal curves with a radius less than 45 m
- as a permanent installation where potential flooding of the highway may occur

For restriction when installed in conjunction with curb, refer to **Section H4.3**.

End Treatments

The currently available end treatment is the Sand Barrel Cushion System for temporary installations. This system is approved under *NCHRP Report 350* as a TL-3 end treatment.

For permanent installations, the same end treatments as for Cast-in-Place or Extruded Concrete Barriers can be used, provided that the precast concrete barrier is sufficiently anchored as per the requirements of the proprietary end treatment system.

For non-NCHRP Report 350-approved end treatments when posted speed is less than or equal to 60 km/h, the Flared and Tapered Down end treatment should be used.

For NCHRP Report 350 approved TL-3 end treatments, the following products are available:

- TRACC
- CAT-350
- QuadGuard.

The TRACC and CAT-350 systems are preferred for lower volume highways with AADT \leq 50,000 vpd where system hits are less likely to occur.

The QuadGuard system is preferred for higher volume highways with AADT $>$ 50,000 vpd.

Additional information on each of the end treatment is provided in **Section H6**.

Transitions

Precast Concrete Barriers may only be transitioned directly to semi-rigid and other rigid barrier systems.

Maintenance Requirements

Typically the barrier should be inspected every construction season to confirm the system is in good working order.

Precast Concrete Barriers generally require some maintenance to ensure the system is functioning properly.

Maintenance inspection activities would typically include checking the following:

- connections between concrete barrier segments
- alignment of the barrier
- condition of the barrier (especially cracking, or damage from traffic or construction equipment).

The potential shifting of the barrier can be minimized if the barrier system is embedded. This will give a smoother line, reducing the chances of snagging at a joint and therefore, reducing the overall crash severity. This will also reduce the inspection effort associated with barrier alignment.

H5.6 References

The following documents were used during the development of this section:

Alberta Infrastructure and Transportation's *Traffic Control Standards Manual*,
Edmonton, AB, 1995

American Association of State Highway and Transportation Officials,
Roadside Design Guide 2002,
Washington, DC, 2002

Canadian Highway Bridge Design Code (CSA-S6-06)

Federal Highway Administration,
Guidelines for Attachments to Bridge Rails and Median Barriers, TRP-03-98-03 Report, February 2003

Joint Cooperative Committee of the American Association of State Highway and Transportation Officials, American Road and Transportation Builders Association, and Associated General Contractors of America,
A Guide to Standardized Highway Barrier Hardware 1995

THIS PAGE LEFT BLANK INTENTIONALLY