

APPENDIX D

GUIDELINES FOR UPGRADING BRIDGE APPROACH RAIL TRANSITIONS

THIS PAGE INTENTIONALLY LEFT BLANK

Appendix D

Guidelines For Upgrading Bridge Approach Rail Transitions

TABLE OF CONTENTS

Appendix	Title
D1	Life-Cycle Benefit-Cost Analysis Procedure for Determining the Need for Bridge Approach Rail Transition Upgrading
D2	Existing INFTRA Bridge Approach Rail Transitions and Corresponding Severity Indices
D3	INFTRA Standard Drawings for Upgrading of Existing Bridge Approach Rail Transitions

THIS PAGE INTENTIONALLY LEFT BLANK

APPENDIX D1

LIFE-CYCLE BENEFIT-COST ANALYSIS PROCEDURE FOR DETERMINING THE NEED FOR BRIDGE APPROACH RAIL TRANSITION UPGRADING

THIS PAGE INTENTIONALLY LEFT BLANK

Appendix D1

Life-Cycle Benefit-Cost Analysis Procedure for Determining the Need for Bridge Approach Rail Transition Upgrading

TABLE OF CONTENTS

Appendix	Title	Page Number
D1.1	Introduction	H-APP-D1-1
D1.2	Warrants for Upgrading Existing Bridge Approach Rail Transitions	H-APP-D1-7
D1.3	Examples – Upgrading Existing Bridge Approach Rail Transitions	H-APP-D1-19

THIS PAGE INTENTIONALLY LEFT BLANK

D1.1 INTRODUCTION

The analysis procedure for establishing the need to upgrade an existing bridge approach rail transition is based on the procedure in the 2003 INFTRA Report entitled “*Guidelines for Upgrading of Existing Bridgerails/Approach Rail Transitions in Alberta.*” As discussed in Appendix C1, this analysis procedure is based on life-cycle benefit-cost analysis. A separate discussion of benefit-cost analysis is provided in Section H.3.3 of the Roadside Design Guide.

The Warrant AADT value required to justify upgrading an approach rail transition is defined as the AADT required for the present worth costs of upgrading (PWC1) to match the present worth costs of not upgrading (PWC2) based on a 2% traffic growth rate and achieving a 4% internal rate of return (IRR) over the project life. The project life is normally chosen to be 20 years, however a shorter time period should be chosen if it is expected that the bridge deck and/or bridgerail curb will be replaced sooner than 20 years.

PWC1 and PWC2 are defined as follows:

- PWC1 = present worth of upgrading costs and collision costs over 20 years or less corresponding to the upgraded bridge approach rail transition.
- PWC2 = present worth of collision costs over 20 years or less corresponding to the existing approach rail transition.

The need for upgrading the approach rail transitions for a particular bridge is determined by the following five step analysis procedure. Step 1 of this procedure begins on the following page.

Note that for the selected bridgerail types shown in Standard Drawings S-1711-07 to S-1720-07, the Warrant AADT may be determined from the Warrant Charts presented in Section HD1.2 of this appendix, rather than by using the following warrant procedure.

For undivided highways, the approach rail transitions will be upgraded the same at all four corners of a bridge, while for divided highways, only the approach rail transitions at the two upstream corners of the bridge require upgrading. In some situations, upgrading of the exit rail transitions at the downstream end of the bridge may be required, as shown on Standard Drawings S-1715-07 and S-1719-07.

Step 1: Approach Rail Transition Upgrading Costs

Determine the total capital costs of upgrading the approach rail transitions at the corners of the bridge requiring upgrading. Divide this total cost by the number of approach rail transitions requiring upgrading to determine the average cost of upgrading one corner of the bridge. This cost must then be converted to year 2000 dollars since the collision costs used by INFTRA are based on year 2000 data (refer to Section H.3.3).

If the approach rail transitions are to be upgraded in accordance with the details shown in INFTRA Standard Drawings S-1711-07 to S-1720-07, then the cost to upgrade the approach rail transition at one corner of a bridge may be taken from Table HD1.1.

Table HD1.1 – Assumed Bridge Approach Rail Transition Upgrading Costs

Approach Rail Transition Upgrading Standard Drawings	Upgrading Costs (per corner of bridge)			
	Year 2000 dollars ¹		Year 2007 dollars	
	Divided Highway	Undivided Highway	Divided Highway	Undivided Highway
Vertical Bar / Horizontal Rail Type Bridgerail on Safety Curb (Standard Drawings S-1711-07 to S-1715-07)	\$ 10,700	\$ 16,400	\$ 16,100	\$ 24,600
850 mm Double Tube Type Bridgerail on Safety Curb (Standard Drawings S-1716-07 to S-1719-07)	\$ 8,600	\$ 11,100	\$ 12,900	\$ 16,700
Single Layer Deep Beam (W-Beam) Bridgerail on Participating Curb (Type 1) – Bridgerail Mounted on 127 mm dia. Std Pipe Posts – Existing Approach Rail Typically not Connected to Bridgerail (Standard Drawing S-1720-07) ²	\$ 4,500	\$ 5,500	\$ 6,800	\$ 8,300
Double Layer Deep Beam (W-Beam) Bridgerail on Participating Curb (Type 2) – Bridgerail Mounted on HSS127x127x6.35 Posts – Existing Approach Rail Typically Continuous with Bridgerail (Standard Drawing S-1720-07) ²	\$ 4,400	\$ 5,300	\$ 6,600	\$ 8,000
Single/Double Layer Deep Beam (W-Beam) Bridgerail on Safety Curb – Bridgerail Mounted on 127 mm dia. Std Pipe Posts – Existing Approach Rail Typically not Connected to Bridgerail (Standard Drawing S-1720-07) ²	\$ 4,600	\$ 5,600	\$ 6,900	\$ 8,400

- ¹ Upgrading costs in year 2000 dollars are used in the warrant analysis procedure to be consistent with the collision costs in Table HC1.7 (Appendix C1) which are also in year 2000 dollars.
- ² Includes cost of upgrading bridgerail.

Step 2: Severity Index (SI) and Corresponding Length (L)

Determine the Severity Index (SI) and corresponding length (L) of the existing approach rail transition. The corresponding length (L) is defined as the length of the approach rail transition that protects the end of the bridgerail and has the assigned severity index. The value “L” should not be confused with the physical length of the overall approach rail transition. Severity Indices and corresponding lengths are provided in Figures HD2.1 to HD2.4 (Appendix D2) for existing approach rail transitions used with different types of bridgerails.

Next, determine the Severity Index (SI) of the proposed upgraded approach rail transition. The SI value for the proposed upgraded approach rail transition must be determined based on the anticipated level of safety that the proposed upgraded transition will provide. To provide uniformity in upgrading bridge approach rail transitions across the province, standard approach rail transition upgrading drawings have been developed for the most common types of existing bridgerails currently on Alberta’s roadways. These drawings are shown in Appendix D3. A summary of SI values are summarized in Table HD1.2:

Table HD1.2 – Standard Approach Rail Transition Upgrading Details and SI Values

Approach Rail Transition Upgrading Standard Drawings	SI Value of Upgraded Approach Rail Transition				
	Design Speed (km/h)				
	60	80	100	110	120
Vertical Bar / Horizontal Rail Type Bridgerail on Safety Curb (Standard Drawings S-1711-07 to S-1715-07)	2.1	2.5	3.1	3.4	3.8
850 mm Double Tube Type Bridgerail on Safety Curb (Standard Drawings S-1716-07 to S-1719-07)	2.1	2.5	3.1	3.4	3.8
Single Layer Deep Beam (W-Beam) Bridgerail on Participating Curb (Type 1) – Bridgerail Mounted on 127 mm dia. Std Pipe Posts – Existing Approach Rail Typically not Connected to Bridgerail (Standard Drawing S-1720-07)	2.1	2.6	3.3	3.6	4.0
Double Layer Deep Beam (W-Beam) Bridgerail on Participating Curb (Type 2) – Bridgerail Mounted on HSS127x127x6.35 Posts – Existing Approach Rail Typically Continuous with Bridgerail (Standard Drawing S-1720-07)	2.1	2.6	3.3	3.6	4.0
Single/Double Layer Deep Beam (W-Beam) Bridgerail on Safety Curb – Bridgerail Mounted on 127 mm dia. Std Pipe Posts – Existing Approach Rail Typically not Connected to Bridgerail (Standard Drawing S-1720-07)	2.1	2.6	3.3	3.6	4.0

For the few existing bridgerail types not listed in Table HD1.2, the upgrading concepts presented in the INFTRA Report entitled “*Guidelines for Upgrading of Existing Bridgerails/Approach Rail Transitions in Alberta*” should be reviewed for selecting an appropriate SI value for the upgraded approach rail transition.

Step 3: Determine Collision Frequency

Determine the collision frequency using the equation:

$$F = 1.6 * R * k_c * k_g * P$$

Where;

F = frequency of approach rail transition collisions (encroachments/km/year)

R = basic encroachment rate for assumed AADT (Appendix C1, Table HC1.1, see note below)

k_c = highway curvature factor (Appendix C1, Table HC1.2)

k_g = highway grade factor (Appendix C1, Table HC1.3)

P = lateral encroachment probability (Appendix C1, Table HC1.4)

Note: The basic encroachment rates shown in Table HC1.1 are multiplied by a factor of 1.6 in Step 3 to obtain the total encroachment rate for all lanes. This adjustment factor is equivalent to the Highway Multi-Lane Factor, k_m , discussed in Appendix C1. Refer to the note in Appendix C1, Section HC1.1, for clarification on the encroachment data presented in Table HC1.1.

Step 4: Present Worth Collision Costs

Determine the Present Worth Collision Costs (PWCC) using the following equation:

$$PWCC = F * k_s * AC * L * KC / 1000$$

Where;

F = frequency of approach rail transition collisions as defined in Step 3 (encroachments/km/year)

k_s = bridge height and occupancy factor (Appendix C1, Table HC1.6)

AC = cost per collision for severity index (Appendix C1, Table HC1.7)

L = length of the existing approach rail transition that protects the end of the bridgerail and which the assigned severity index of the existing approach rail transition is representative (refer to Figure HD2.1 to HD2.4)

KC = present worth conversion factor. Annual collision costs are converted to present worth at a discount rate of 4% and a traffic growth rate of 2%. If the project life is 20 years, KC is equal to 16.252. If the project life is less than 20 years due to the condition of the existing bridge, then a different present worth conversion factor value must be used in accordance with Table HC1.8 in Appendix C1.

Step 5: Determining “PWC1” and “PWC2”

“PWC1” is calculated by adding together the 1) present worth cost of upgrading the bridge approach rail transition (per corner of bridge) and 2) the present worth collision costs (per corner of bridge) determined in Step 4 for the upgraded approach rail transition.

“PWC2” is the present worth collision costs determined in Step 4 for the existing approach rail transition (per corner of bridge).

Conclusion: The alternative with the lowest present worth cost is the recommended alternative.

Step 6 (OPTIONAL): Iterating to Solve for the Warrant AADT

Steps 3 to 5 are repeated for different values of AADT until PWC1 equals PWC2. The AADT that yields PWC1 equal to PWC2 is the “Warrant AADT”. Upgrading of the bridge approach rail transition is warranted when the traffic volume is equal to or greater than the Warrant AADT value.

D1.2 WARRANTS FOR UPGRADING EXISTING BRIDGE APPROACH RAIL TRANSITIONS

The Warrant Charts presented in this appendix shall be used for determining the need for upgrading the approach rail transitions for the following types of existing bridgerails:

Table HD1.3 – Warrant Charts for Upgrading Bridge Approach Rail Transitions

Bridgerail Type	Highway Type	Standard Drawing	Warrant Chart
Vertical Bar / Horizontal Rail	Undivided	S-1711-07 and S-1712-07	Figures HD1.1A and HD1.1B
Vertical Bar / Horizontal Rail	Divided	S-1713-07 to S-1715-07	Figures HD1.2A and HD1.2B
850 mm Double Tube	Undivided	S-1716-07 to S-1718-07	Figures HD1.3A and HD1.3B
850 mm Double Tube	Divided	S-1716-07 to S-1719-07	Figures HD1.4A and HD1.4B
Single Layer Deep Beam on Participating Curb (Type 1) ¹	Undivided	S-1720-07	Figures HD1.5A and HD1.5B
Single Layer Deep Beam on Participating Curb (Type 1) ¹	Divided	S-1720-07	Figures HD1.6A and HD1.6B
Double Layer Deep Beam on Participating Curb (Type 2) ²	Undivided	S-1720-07	Figures HD1.7A and HD1.7B
Double Layer Deep Beam on Participating Curb (Type 2) ²	Divided	S-1720-07	Figures HD1.8A and HD1.8B
Single or Double Layer Deep Beam on Safety Curb ¹	Undivided	S-1720-07	Figures HD1.9A and HD1.9B
Single or Double Layer Deep Beam on Safety Curb ¹	Divided	S-1720-07	Figures HD1.10A and HD1.10B

¹ Bridgerail Mounted on 127 mm dia. Std Pipe Posts – Existing Approach Rail Typically not Connected to Bridgerail.

² Bridgerail Mounted on HSS127x127x6.35 Posts – Existing Approach Rail Typically Continuous with Bridgerail.

These Warrant Charts have been created following the six step warranting procedure in Section HD1.1. They may be used for quickly establishing the Warrant AADT necessary to justify the upgrade of existing bridge approach rail transitions. The Warrant AADT is a function of the following variables:

- Highway Design Speed
- Highway Shoulder Width
- Highway Curvature, k_c (refer to Table HC1.2 in Appendix C1)
- Highway Grade, k_g (refer to Table HC1.3 in Appendix C1)
- Bridge Height and Occupancy, k_s (refer to Table HC1.6 in Appendix C1)

The approach rail transition warrant charts presented in Figures HD1.1A to HD1.10B are based on:

- the assumed capital costs for upgrading stated previously in Table HD1.1
- the SI values for the upgraded approach rail transitions summarized in Table HD1.2
- the SI and corresponding length values for the existing approach rail transitions shown in Figure HD2.1 to HD2.4 in Appendix D2
- a 20 year project life with a 4% discount rate and a 2% traffic growth rate.

The warrant charts are presented as two sets of curves per page to allow for linear interpolation. The set of curves in the top figure, labeled as Figure A, are based on holding the product of $k_c * k_g * k_s$ equal to 0.7; the set of curves in the bottom figure, labeled as Figure B, are based on holding the product of $k_c * k_g * k_s$ equal to 2.0. Intermediate values of $k_c * k_g * k_s$ can be calculated by linear interpolation between the two sets of curves. For values of $k_c * k_g * k_s$ exceeding 2.0, the six step detailed warrant procedure stated above should be followed.

The approach rail transition should be upgraded if the actual AADT is equal to or greater than the Warrant AADT value.

FIGURE HD1.1A: APPROACH RAIL TRANSITION UPGRADE WARRANTS FOR "VERTICAL BAR / HORIZONTAL RAIL" TYPE BRIDGERAIL - UNDIVIDED ROADWAYS (REFER TO STANDARD DRAWINGS S-1711-07 AND S-1712-07)

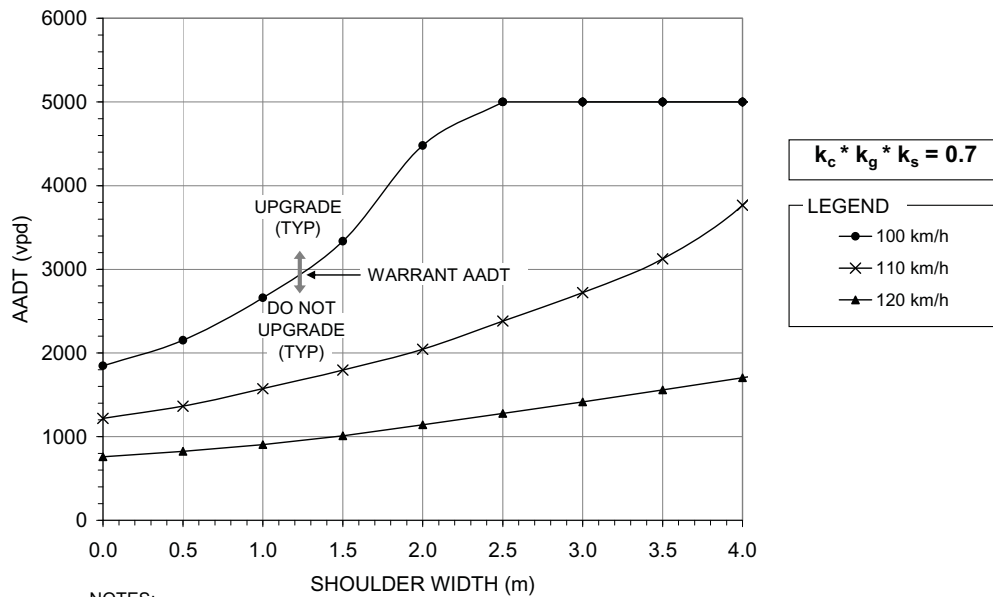

NOTES:

- UPGRADES ARE NOT WARRANTED FOR DESIGN SPEEDS LESS THAN 100 km/h.
- ASSUME A WARRANT AADT OF 5000 vpd FOR THE DESIGN SPEED OF 80 km/h FOR INTERPOLATION USE ONLY BETWEEN FIGURES HD1.1A AND HD1.1B.
- AADT IS THE TOTAL VOLUME OF TRAFFIC IN BOTH DIRECTIONS.

FIGURE HD1.1B: APPROACH RAIL TRANSITION UPGRADE WARRANTS FOR "VERTICAL BAR / HORIZONTAL RAIL" TYPE BRIDGERAIL - UNDIVIDED ROADWAYS (REFER TO STANDARD DRAWINGS S-1711-07 AND S-1712-07)

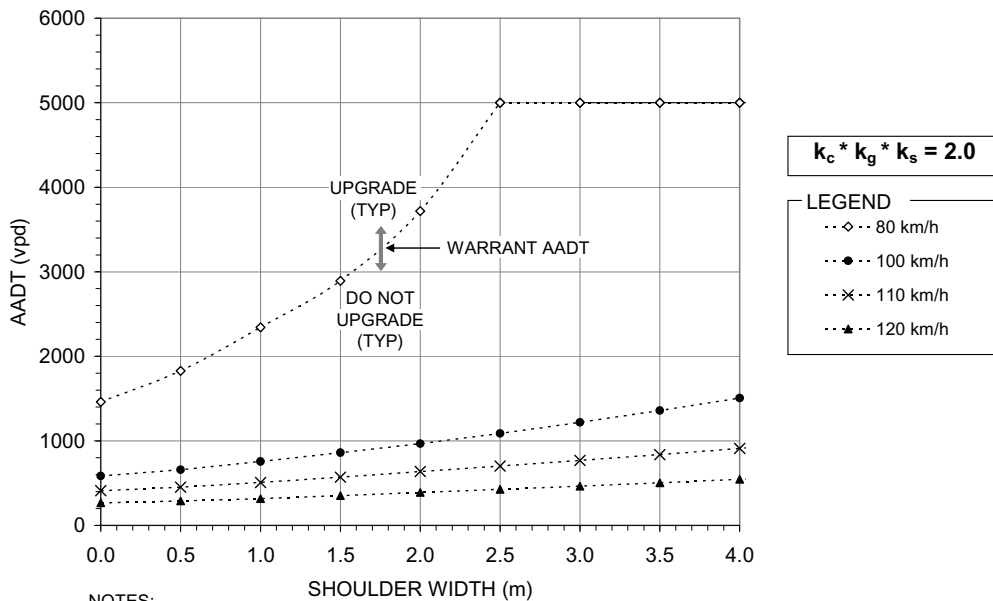

NOTES:

- UPGRADES ARE NOT WARRANTED FOR DESIGN SPEEDS LESS THAN 80 km/h.
- AADT IS THE TOTAL VOLUME OF TRAFFIC IN BOTH DIRECTIONS.

FIGURE HD1.2A: APPROACH RAIL TRANSITION UPGRADE WARRANTS FOR "VERTICAL BAR / HORIZONTAL RAIL" TYPE BRIDGERAIL - DIVIDED ROADWAYS (REFER TO STANDARD DRAWINGS S-1713-07 TO S-1715-07)

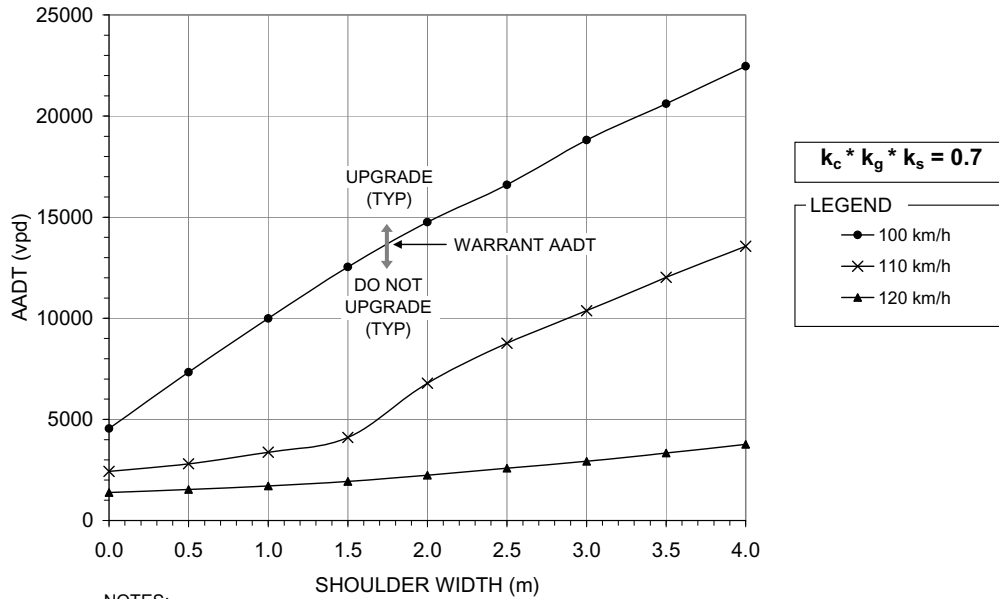

NOTES:

- UPGRADES ARE NOT WARRANTED FOR DESIGN SPEEDS LESS THAN 100 km/h.
- ASSUME A WARRANT AADT OF 25000 vpd FOR THE DESIGN SPEED OF 80 km/h FOR INTERPOLATION USE ONLY BETWEEN FIGURES HD1.2A AND HD1.2B.
- AADT IS THE TOTAL VOLUME OF TRAFFIC IN BOTH DIRECTIONS.

FIGURE HD1.2B: APPROACH RAIL TRANSITION UPGRADE WARRANTS FOR "VERTICAL BAR / HORIZONTAL RAIL" TYPE BRIDGERAIL - DIVIDED ROADWAYS (REFER TO STANDARD DRAWINGS S-1713-07 TO S-1715-07)

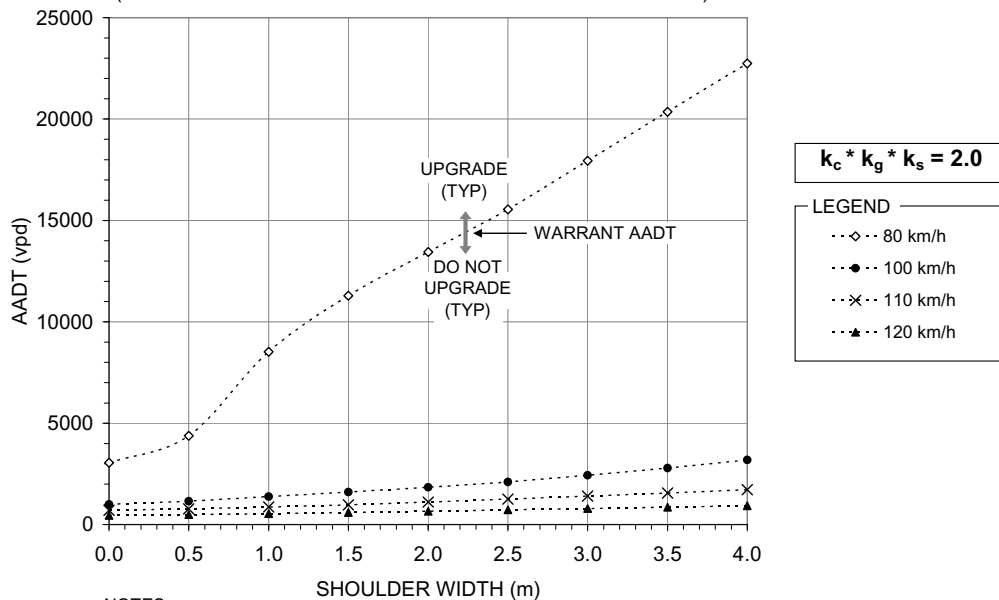

NOTES:

- UPGRADES ARE NOT WARRANTED FOR DESIGN SPEEDS LESS THAN 80 km/h.
- AADT IS THE TOTAL VOLUME OF TRAFFIC IN BOTH DIRECTIONS.

FIGURE HD1.3A: APPROACH RAIL TRANSITION UPGRADE WARRANTS FOR "850 mm DOUBLE TUBE" TYPE BRIDGERAIL - UNDIVIDED ROADWAYS (REFER TO STANDARD DRAWINGS S-1716-07 TO S-1718-07)

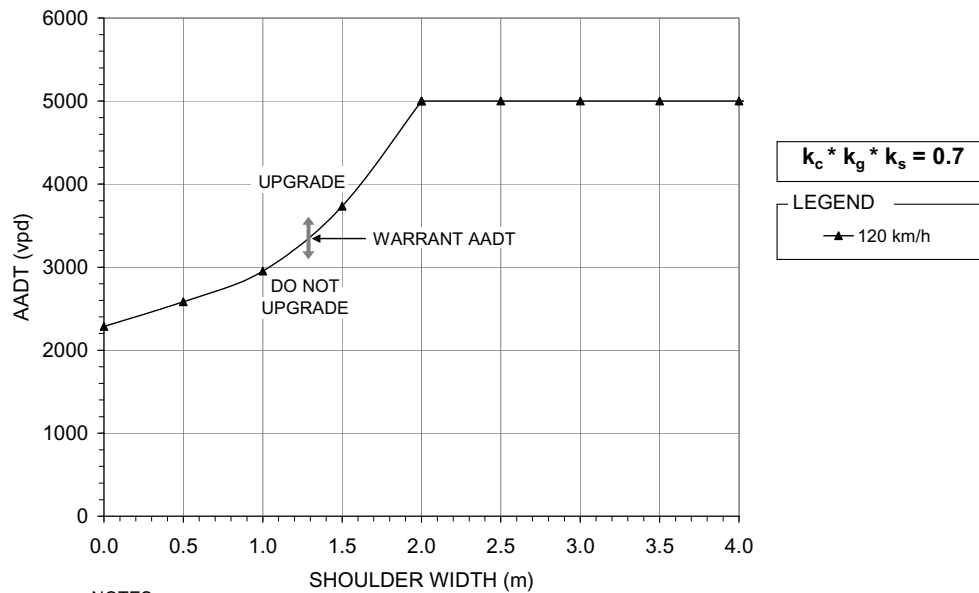

NOTES:

- UPGRADES ARE NOT WARRANTED FOR DESIGN SPEEDS LESS THAN 120 km/h.
- ASSUME A WARRANT AADT OF 5000 vpd FOR THE DESIGN SPEED OF 100 km/h AND 110 km/h FOR INTERPOLATION USE ONLY BETWEEN FIGURES HD1.3A AND HD1.3B.
- AADT IS THE TOTAL VOLUME OF TRAFFIC IN BOTH DIRECTIONS.

FIGURE HD1.3B: APPROACH RAIL TRANSITION UPGRADE WARRANTS FOR "850 mm DOUBLE TUBE" TYPE BRIDGERAIL - UNDIVIDED ROADWAYS (REFER TO STANDARD DRAWINGS S-1716-07 TO S-1718-07)

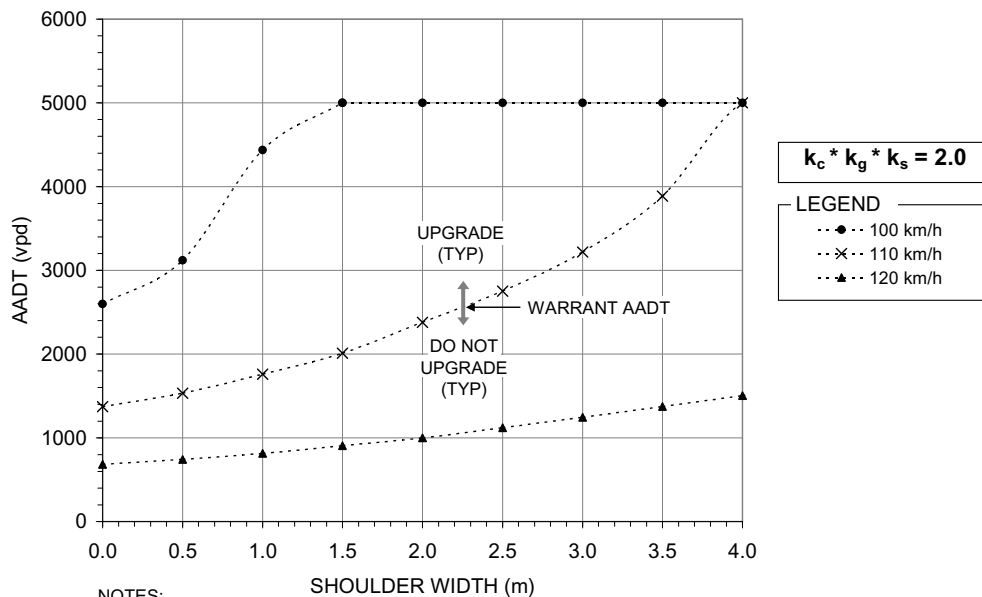

NOTES:

- UPGRADES ARE NOT WARRANTED FOR DESIGN SPEEDS LESS THAN 100 km/h.
- AADT IS THE TOTAL VOLUME OF TRAFFIC IN BOTH DIRECTIONS.

FIGURE HD1.4A: APPROACH RAIL TRANSITION UPGRADE WARRANTS FOR "850 mm DOUBLE TUBE" TYPE BRIDGERAIL - DIVIDED ROADWAYS (REFER TO STANDARD DRAWINGS S-1716-07 TO S-1719-07)

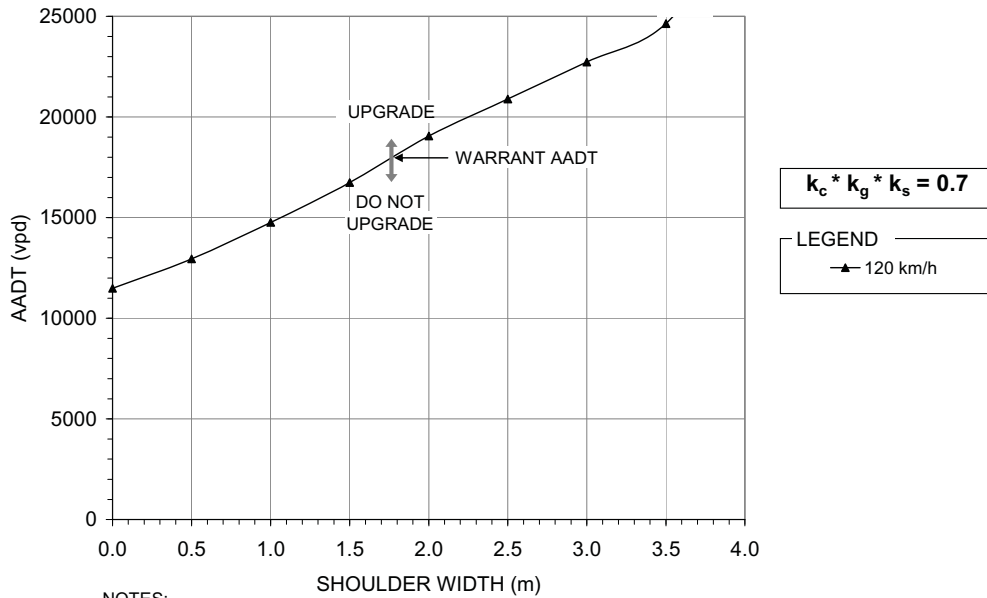

NOTES:

- UPGRADES ARE NOT WARRANTED FOR DESIGN SPEEDS LESS THAN 120 km/h.
- ASSUME A WARRANT AADT OF 25000 vpd FOR DESIGN SPEEDS OF 100 km/h AND 110 kph FOR INTERPOLATION USE ONLY BETWEEN FIGURES HD1.4A AND HD1.4B.
- AADT IS THE TOTAL VOLUME OF TRAFFIC IN BOTH DIRECTIONS.

FIGURE HD1.4B: APPROACH RAIL TRANSITION UPGRADE WARRANTS FOR "850 mm DOUBLE TUBE" TYPE BRIDGERAIL - DIVIDED ROADWAYS (REFER TO STANDARD DRAWINGS S-1716-07 TO S-1719-07)

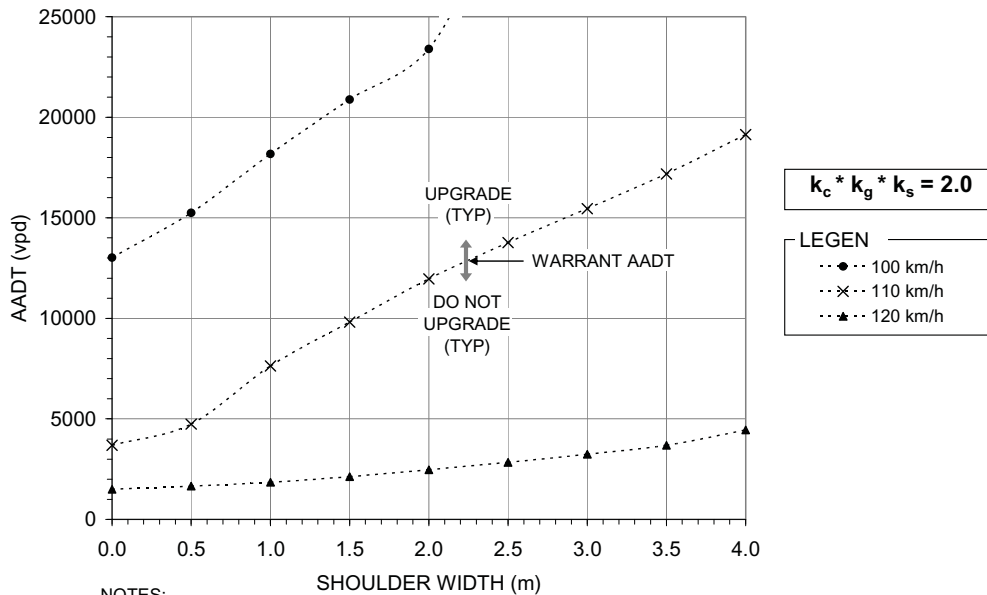

NOTES:

- UPGRADES ARE NOT WARRANTED FOR DESIGN SPEEDS LESS THAN 100 km/h.
- AADT IS THE TOTAL VOLUME OF TRAFFIC IN BOTH DIRECTIONS.

FIGURE HD1.5A: APPROACH RAIL TRANSITION UPGRADE WARRANTS FOR "SINGLE LAYER DEEP BEAM (W-BEAM)" TYPE BRIDGERAIL ON TYPE 1 PARTICIPATING CURB - UNDIVIDED ROADWAYS (REFER TO STANDARD DRAWING S-1720-07)

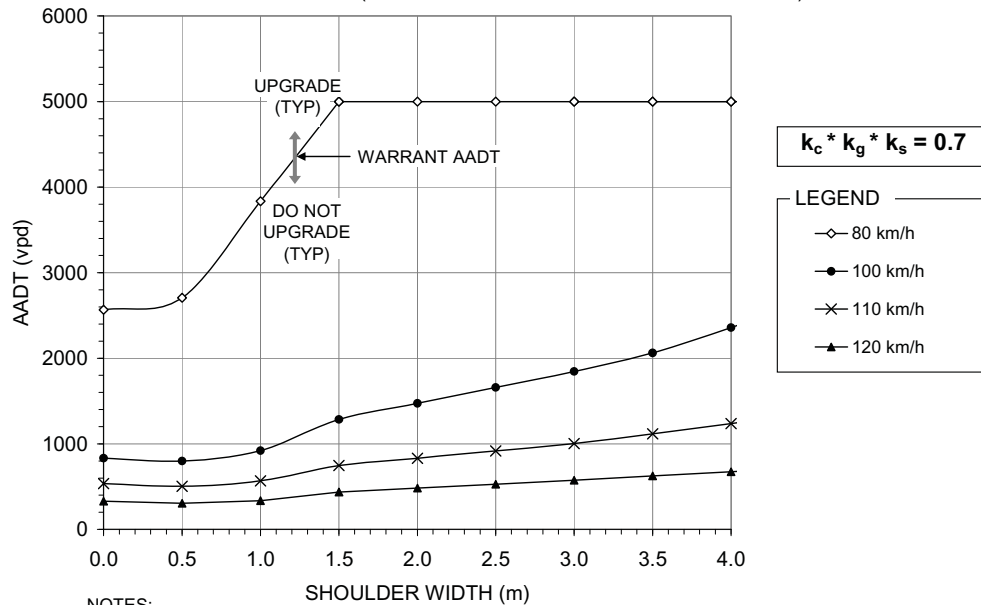

NOTES:

- UPGRADES ARE NOT WARRANTED FOR DESIGN SPEEDS LESS THAN 80 km/h.
- AADT IS THE TOTAL VOLUME OF TRAFFIC IN BOTH DIRECTIONS.

FIGURE HD1.5B: APPROACH RAIL TRANSITION UPGRADE WARRANTS FOR "SINGLE LAYER DEEP BEAM (W-BEAM)" TYPE BRIDGERAIL ON TYPE 1 PARTICIPATING CURB - UNDIVIDED ROADWAYS (REFER TO STANDARD DRAWING S-1720-07)

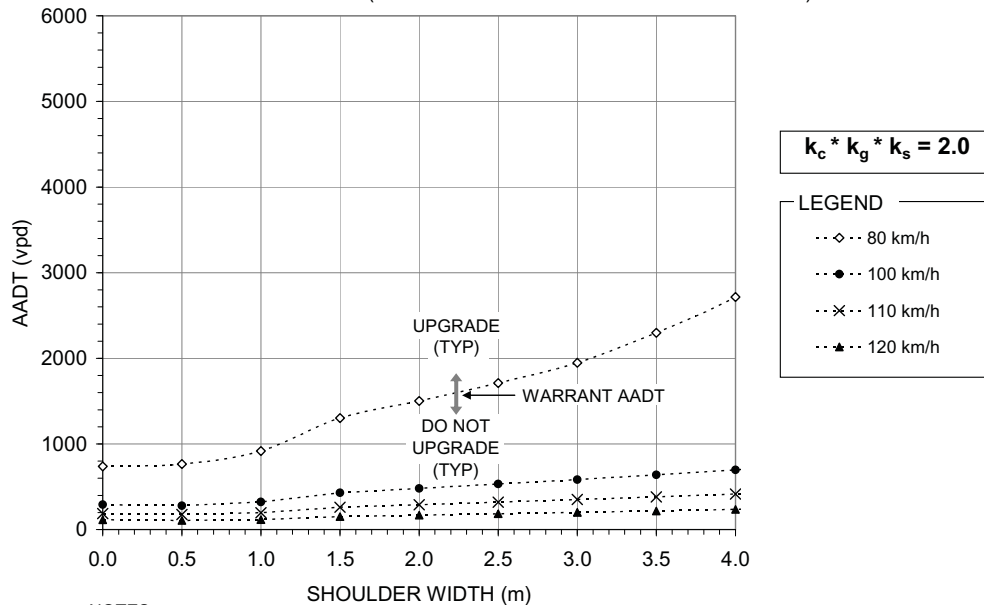

NOTES:

- UPGRADES ARE NOT WARRANTED FOR DESIGN SPEEDS LESS THAN 80 km/h.
- AADT IS THE TOTAL VOLUME OF TRAFFIC IN BOTH DIRECTIONS.

FIGURE HD1.6A: APPROACH RAIL TRANSITION UPGRADE WARRANTS FOR "SINGLE LAYER DEEP BEAM (W-BEAM)" TYPE BRIDGERAIL ON TYPE 1 PARTICIPATING CURB - DIVIDED ROADWAYS (REFER TO STANDARD DRAWING S-1720-07)

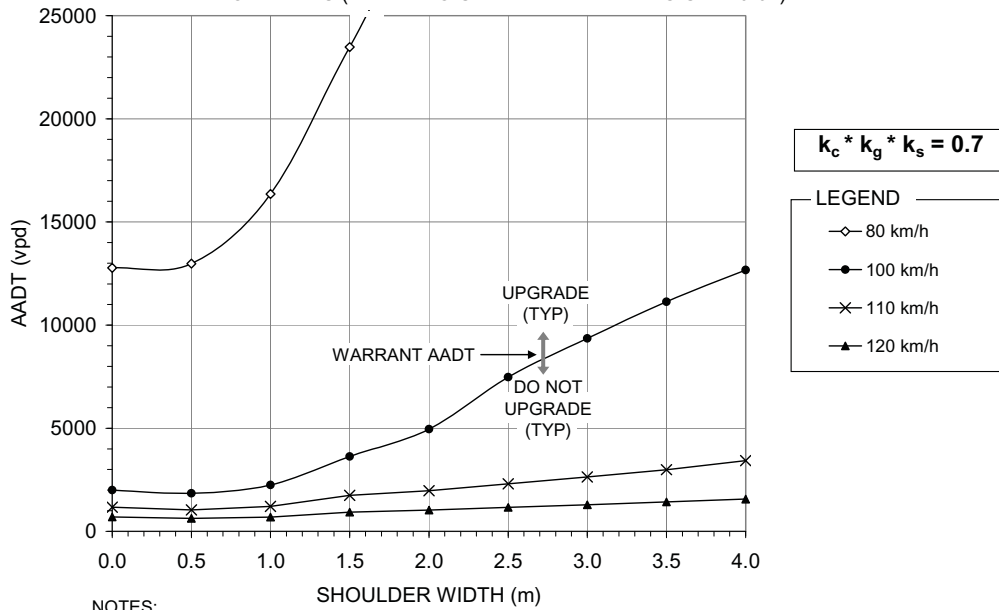

NOTES:

- UPGRADES ARE NOT WARRANTED FOR DESIGN SPEEDS LESS THAN 80 km/h.
- AADT IS THE TOTAL VOLUME OF TRAFFIC IN BOTH DIRECTIONS.

FIGURE HD1.6B: APPROACH RAIL TRANSITION UPGRADE WARRANTS FOR "SINGLE LAYER DEEP BEAM (W-BEAM)" TYPE BRIDGERAIL ON TYPE 1 PARTICIPATING CURB - DIVIDED ROADWAYS (REFER TO STANDARD DRAWING S-1720-07)

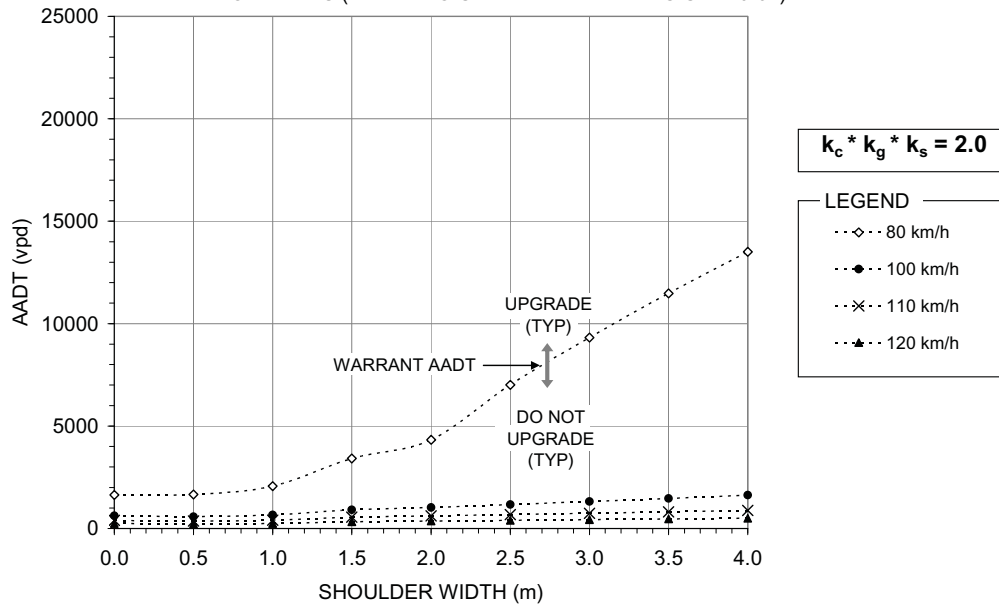

NOTES:

- UPGRADES ARE NOT WARRANTED FOR DESIGN SPEEDS LESS THAN 80 km/h.
- AADT IS THE TOTAL VOLUME OF TRAFFIC IN BOTH DIRECTIONS.

FIGURE HD1.7A: APPROACH RAIL TRANSITION UPGRADE WARRANTS FOR "DOUBLE LAYER DEEP BEAM (W-BEAM)" TYPE BRIDGERAIL ON TYPE 2 PARTICIPATING CURB - UNDIVIDED ROADWAYS (REFER TO STANDARD DRAWING S-1720-07)

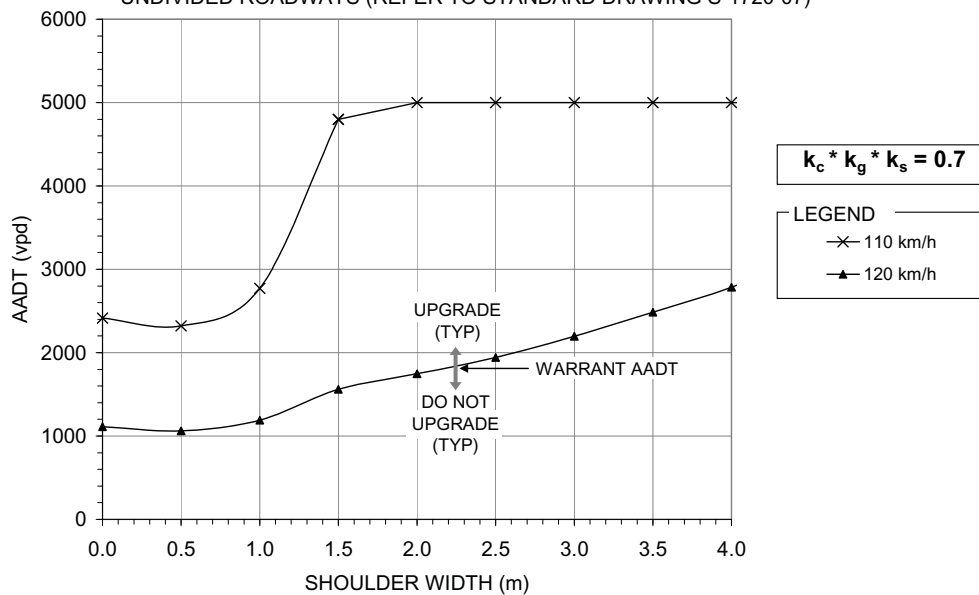

NOTES:

- UPGRADES ARE NOT WARRANTED FOR DESIGN SPEEDS LESS THAN 110 km/h.
- ASSUME A WARRANT AADT OF 5000 vpd FOR THE DESIGN SPEED OF 100 km/h FOR INTERPOLATION USE ONLY BETWEEN FIGURES HD1.7A AND HD1.7B.
- FOR DOUBLE-LAYER DEEP BEAM TYPE BRIDGERAIL WITH 127 mm DIAMETER PIPE POST AT 1905 mm (MAX) SPACING ON TYPE 1 PARTICIPATING CURB, USE FIGURE HD1.5A.
- AADT IS THE TOTAL VOLUME OF TRAFFIC IN BOTH DIRECTIONS.

FIGURE HD1.7B: APPROACH RAIL TRANSITION UPGRADE WARRANTS FOR "DOUBLE LAYER DEEP BEAM (W-BEAM)" TYPE BRIDGERAIL ON TYPE 2 PARTICIPATING CURB - UNDIVIDED ROADWAYS (REFER TO STANDARD DRAWING S-1720-07)

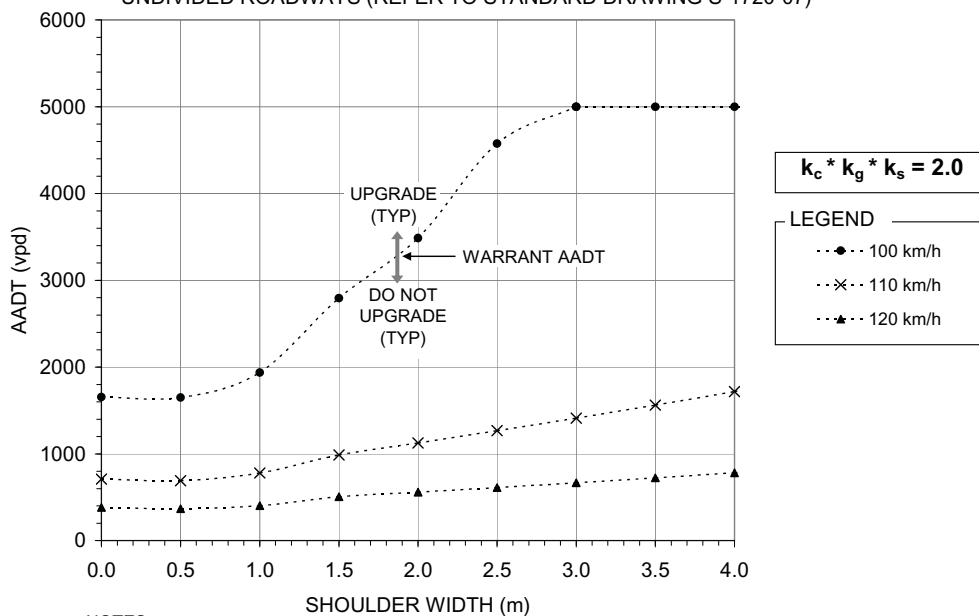

NOTES:

- UPGRADES ARE NOT WARRANTED FOR DESIGN SPEEDS LESS THAN 100 km/h.
- FOR DOUBLE-LAYER DEEP BEAM TYPE BRIDGERAIL WITH 127 mm DIAMETER STANDARD PIPE POST AT 1905 mm (MAX) SPACING ON TYPE 1 PARTICIPATING CURB, USE FIGURE HD1.5B.
- AADT IS THE TOTAL VOLUME OF TRAFFIC IN BOTH DIRECTIONS.

FIGURE HD1.8A: APPROACH RAIL TRANSITION UPGRADE WARRANTS FOR "DOUBLE LAYER DEEP BEAM (W-BEAM)" TYPE BRIDGERAIL ON TYPE 2 PARTICIPATING CURB - DIVIDED ROADWAYS (REFER TO STANDARD DRAWING S-1720-07)

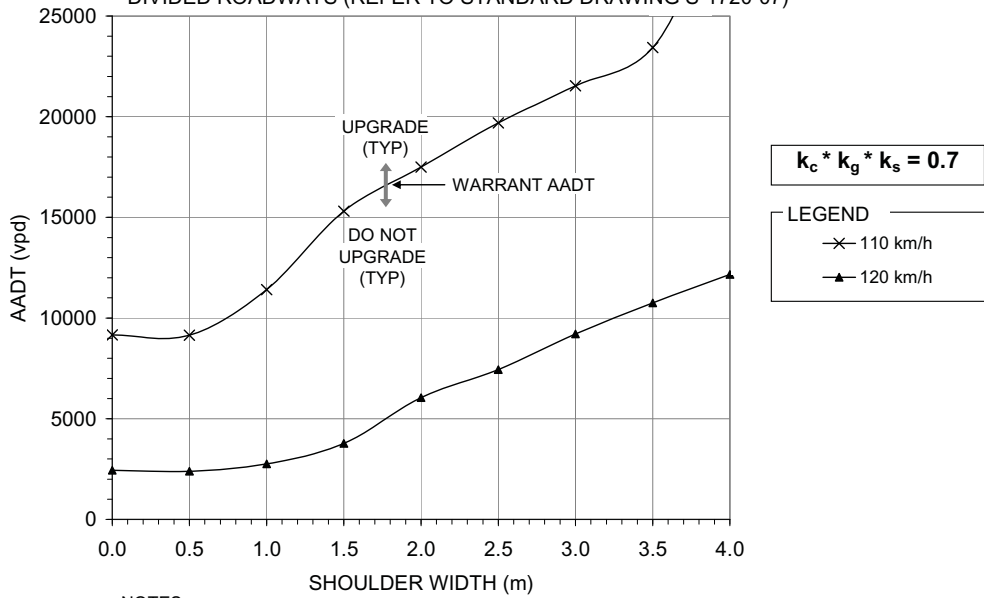

NOTES:

- UPGRADES ARE NOT WARRANTED FOR DESIGN SPEEDS LESS THAN 110 km/h.
- ASSUME A WARRANT AADT OF 25000 vpd FOR THE DESIGN SPEED OF 100 km/h FOR INTERPOLATION USE ONLY BETWEEN FIGURES HD1.8A AND HD1.8B.
- FOR DOUBLE-LAYER DEEP BEAM TYPE BRIDGERAIL WITH 127 mm DIAMETER PIPE POST AT 1905 mm (MAX) SPACING ON TYPE 1 PARTICIPATING CURB, USE FIGURE HD1.6A.
- AADT IS THE TOTAL VOLUME OF TRAFFIC IN BOTH DIRECTIONS.

FIGURE HD1.8B: APPROACH RAIL TRANSITION UPGRADE WARRANTS FOR "DOUBLE LAYER DEEP BEAM (W-BEAM)" TYPE BRIDGERAIL ON TYPE 2 PARTICIPATING CURB - DIVIDED ROADWAYS (REFER TO STANDARD DRAWING S-1720-07)

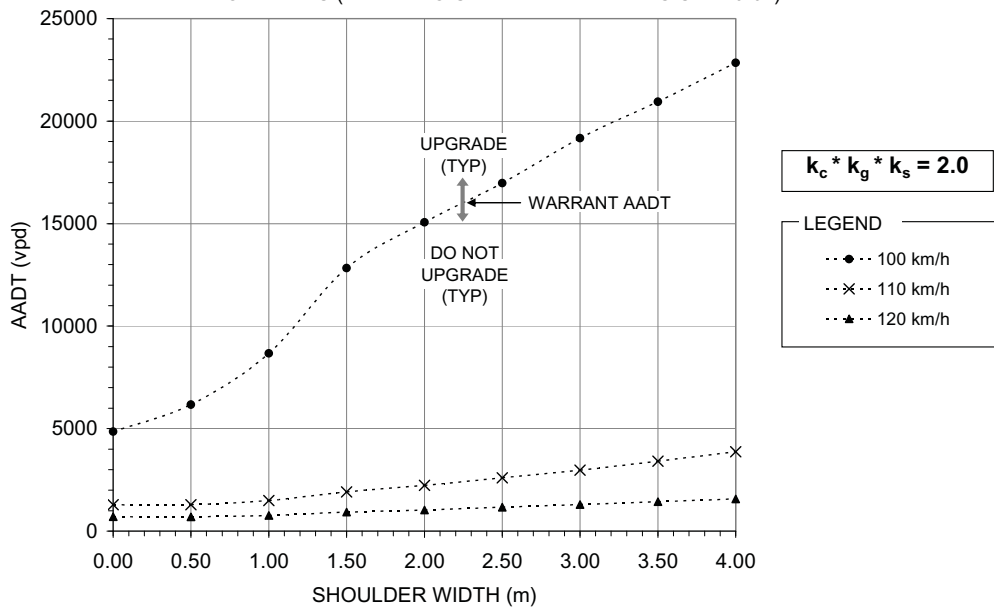

NOTES:

- UPGRADES ARE NOT WARRANTED FOR DESIGN SPEEDS LESS THAN 100 km/h.
- FOR DOUBLE-LAYER DEEP BEAM TYPE BRIDGERAIL WITH 127 mm DIAMETER STANDARD PIPE POST AT 1905 mm (MAX) SPACING ON TYPE 1 PARTICIPATING CURB, USE FIGURE HD1.6B.
- AADT IS THE TOTAL VOLUME OF TRAFFIC IN BOTH DIRECTIONS.

FIGURE HD1.9A: APPROACH RAIL TRANSITION UPGRADE WARRANTS FOR "SINGLE OR DOUBLE LAYER DEEP BEAM" TYPE BRIDGERAIL ON SAFETY CURB - UNDIVIDED ROADWAYS (REFER TO STANDARD DRAWING S-1720-07)

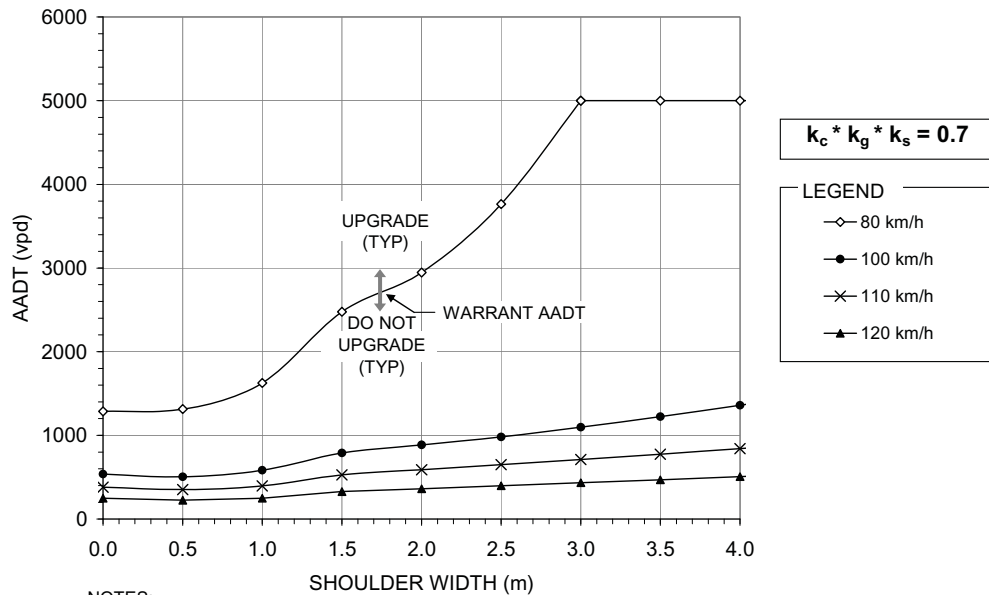

NOTES:

- UPGRADES ARE NOT WARRANTED FOR DESIGN SPEEDS LESS THAN 80 km/h.
- ASSUME A WARRANT AADT OF 5000 vpd FOR THE DESIGN SPEED OF 60 km/h FOR INTERPOLATION USE ONLY BETWEEN FIGURES HD1.9A AND HD1.9B.
- AADT IS THE TOTAL VOLUME OF TRAFFIC IN BOTH DIRECTIONS.

FIGURE HD1.9B: APPROACH RAIL TRANSITION UPGRADE WARRANTS FOR "SINGLE OR DOUBLE LAYER DEEP BEAM" TYPE BRIDGERAIL ON SAFETY CURB - UNDIVIDED ROADWAYS (REFER TO STANDARD DRAWING S-1720-07)

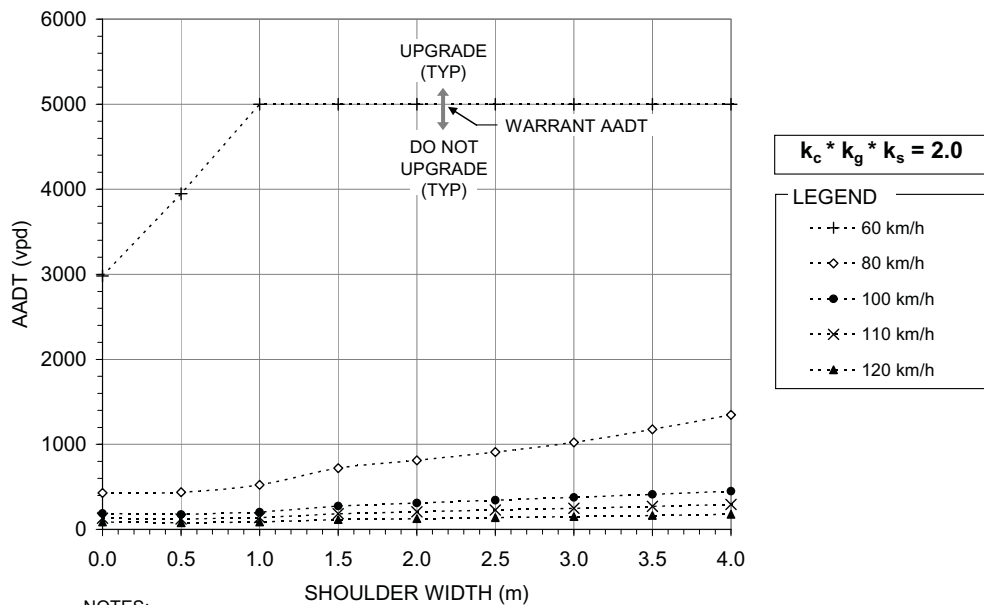

NOTES:

- UPGRADES ARE NOT WARRANTED FOR DESIGN SPEEDS LESS THAN 60 km/h.
- AADT IS THE TOTAL VOLUME OF TRAFFIC IN BOTH DIRECTIONS.

FIGURE HD1.10A: APPROACH RAIL TRANSITION UPGRADE WARRANTS FOR "SINGLE OR DOUBLE LAYER DEEP BEAM" TYPE BRIDGERAIL ON SAFETY CURB - DIVIDED ROADWAYS (REFER TO STANDARD DRAWING S-1720-07)

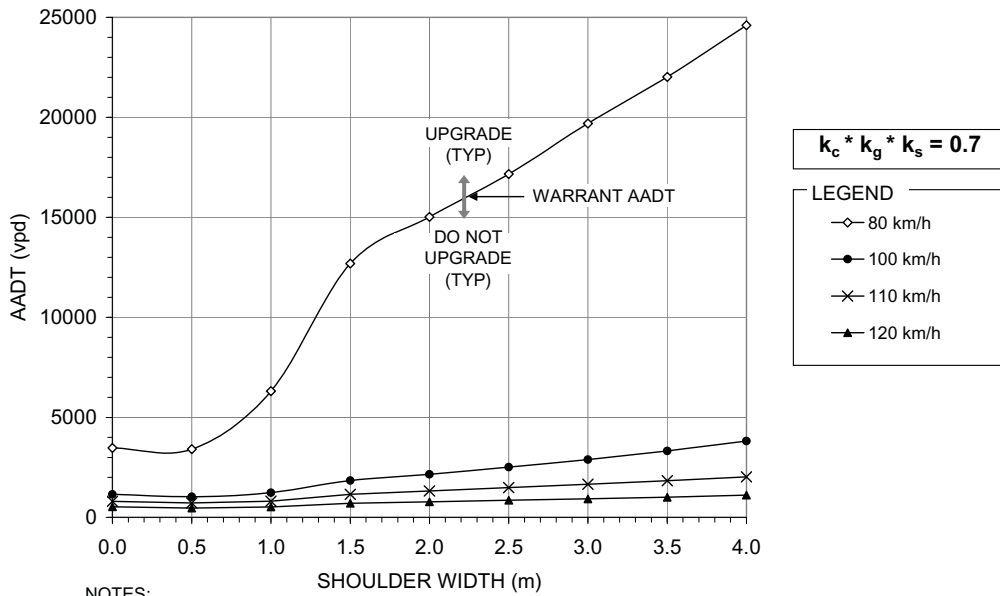

NOTES:

- UPGRADES ARE NOT WARRANTED FOR DESIGN SPEEDS LESS THAN 80 km/h.
- ASSUME A WARRANT AADT OF 25000 vpd FOR THE DESIGN SPEED OF 60 km/h FOR INTERPOLATION USE ONLY BETWEEN FIGURES HD1.10A AND HD1.10B.
- AADT IS THE TOTAL VOLUME OF TRAFFIC IN BOTH DIRECTIONS.

FIGURE HD1.10B: APPROACH RAIL TRANSITION UPGRADE WARRANTS FOR "SINGLE OR DOUBLE LAYER DEEP BEAM" TYPE BRIDGERAIL ON SAFETY CURB - DIVIDED ROADWAYS (REFER TO STANDARD DRAWING S-1720-07)

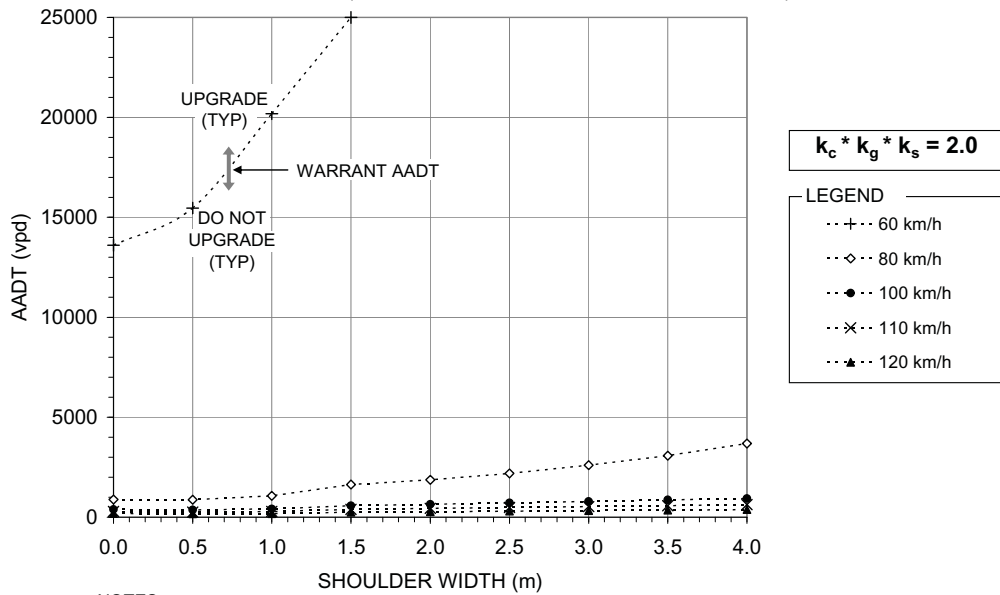

NOTES:

- UPGRADES ARE NOT WARRANTED FOR DESIGN SPEEDS LESS THAN 60 km/h.
- AADT IS THE TOTAL VOLUME OF TRAFFIC IN BOTH DIRECTIONS.

D1.3 EXAMPLES - UPGRADING EXISTING BRIDGE APPROACH RAIL TRANSITIONS

The three bridgerail upgrading examples from Appendix C1 are continued below to demonstrate the steps required to determine the Warrant AADT for upgrading the approach rail transitions. In the first example, the product of factors $k_c * k_g * k_s$ is greater than 2.0 which is outside the realm of the approach rail transition upgrading warrant charts. Therefore, the decision of whether or not to upgrade the approach rail transition is based on following the six step detailed warrant procedure. In the second example, the product of factors $k_c * k_g * k_s$ is equal to 0.70, allowing the warrant charts to be used directly. In the third example, the product of $k_c * k_g * k_s$ is between 0.7 and 2.0, and therefore the Warrant AADT is determined using linear interpolation between the warrant chart curves.

EXAMPLE 1 – BRIDGE #1

($k_c * k_g * k_s$ greater than 2.0)

Bridge and Highway Data:

- Refer to Example 1 in Appendix C1
- Refer to Standard Drawings S-1711-07 to S-1715-07 for approach rail upgrading details.

Calculations:

- $k_c = 1.9$ from Table HC1.2 (Appendix C1)
- $k_g = 1.0$ from Table HC1.3 (Appendix C1)
- $k_s = 1.3$ from Table HC1.6 (Appendix C1)
- Since the product $k_c * k_g * k_s$ is greater than 2.0, the need for approach rail transition upgrading must be determined using the detailed six step procedure.
 - Step 1 – Upgrading Costs
 - Cost to upgrade the approach rail transition is \$16,400 per corner of bridge, in year 2000 dollars (Table HD1.1)
 - Step 2 – Severity Index (SI) and Corresponding Length (L)
 - SI of the upgraded approach rail transition is 3.1 (Table HD1.2)
 - SI of the existing approach rail transition is 5.6 with a corresponding length of 8.5 m (Figure HD2.1, Appendix D2)

- Step 3 – Collision Frequency
 - $R = 0.53$ based on linear interpolation with AADT = 1700 (Table HC1.1, Appendix C1)
 - $P = 0.7965$ based on linear interpolation with a shoulder width of 0.90 m at a design speed of 100 km/h (Table HC1.4, Appendix C1)
 - $F = R * k_c * k_g * P = 0.80$ encroachments/km/year
- Step 4 – Present Worth Collision Costs ($PWCC = F * k_s * AC * L * KC / 1000$)
 - AC1 (upgrade) = \$78,000 based on linear interpolation (Table HC1.7, Appendix C1)
 - AC2 (no upgrade) = \$265,000 (Table HC1.7, Appendix C1)
 - $L = 8.5$ m (Step 2)
 - $KC = 16.252$
 - PWCC1 (upgrade) = \$11,200 collision costs per corner of bridge over 20 years
 - PWCC2 (no upgrade) = \$38,100 collision costs per corner of bridge over 20 years
- Step 5 – Determining PWC1 and PWC2
 - PWC1 = \$16,400 (approach rail transition upgrade cost per corner of bridge) plus \$11,200 (collision costs of the upgraded approach rail transition per corner of bridge over 20 years) = \$27,600
 - PWC2 = \$38,100 (collision costs of the existing approach rail transition per corner of bridge over 20 years)

Conclusion: Since PWC1 (upgrade) < PWC2 (no upgrade), upgrading the approach rail transition at each corner of the bridge is warranted.

- Step 6 (OPTIONAL) – Iterating to Solve for the “Warrant AADT”
 - The table below summarizes the trial and error results of determining the Warrant AADT:

Assumed Warrant AADT	PWC1 (upgrade)	PWC2 (no upgrade)
600	\$ 20,700	\$ 14,700
700	\$ 21,400	\$ 17,100
800	\$ 22,200	\$ 19,600
900	\$ 22,900	\$ 22,000
950	\$ 23,200	\$ 23,300
952	\$ 23,300	\$ 23,300

Therefore the Warrant AADT is 952 vpd.

Conclusion:

Since the actual AADT of 1700 vpd > the Warrant AADT of 952 vpd, upgrading of the approach rail transition is warranted at each corner of the bridge.

Note that in Example 1 in Appendix C1, it was determined that the bridgerail should be upgraded. Therefore, the approach rail transition would be upgraded by default, regardless of the conclusion noted above.

EXAMPLE 2 – BRIDGE #2

($k_c * k_g * k_s$ equal to 0.70)

Bridge and Highway Data:

- Refer to Example 2 in Appendix C1
- Refer to Standard Drawings S-1720-07 for approach rail upgrading details.

Calculations:

- $k_c = 1.0$ from Table HC1.2 (Appendix C1)
- $k_g = 1.0$ from Table HC1.3 (Appendix C1)
- $k_s = 0.70$ Table HC1.6 (Appendix C1)
- Since the product $k_c * k_g * k_s$ is equal to 0.70, the Warrant Chart in Figure HD1.9A may be used directly.
- From Figure HD1.9A, the “Warrant AADT” corresponding to a shoulder width of 1.8 m and a design speed of 100 km/h is approximately 920 vpd.

Conclusion:

Since the actual AADT of 2500 vpd > the Warrant AADT of 920 vpd, upgrading of the approach rail transition is warranted at each corner of the bridge.

Note that in Example 2 in Appendix C1, it was determined that the bridgerail should not be upgraded. However, upgrading of the approach rail transition is still required.

EXAMPLE 3 – BRIDGE #3

($k_c * k_g * k_s$ between 0.70 and 2.0)

Bridge and Highway Data:

- Refer to Example 3 in Appendix C1
- Refer to Standard Drawings S-1716-07 to S-1719-07 for approach rail upgrading details.

Calculations:

- $k_c = 1.0$ from Table HC1.2 (Appendix C1)
- $k_g = 1.0$ from Table HC1.3 (Appendix C1)
- $k_s = 0.88$ from Table HC1.6 (Appendix C1)
- Since the product $k_c * k_g * k_s$ is between 0.70 and 2.0, the Warrant AADT may be determined by linearly interpolating between the warrant charts in Figures HD1.4A and HD1.4B.
 - From Figure HD1.4A, the Warrant AADT corresponding to a shoulder width of 2.5 m and a design speed of 110 km/h is 25,000 vpd for $k_c * k_g * k_s = 0.7$.
 - From Figure HD1.4B, the Warrant AADT corresponding to a shoulder width of 2.5 m and a design speed of 110 km/h is 13,800 vpd for $k_c * k_g * k_s = 2.0$.
 - Using linear interpolation, the Warrant AADT is calculated as follows:

$$\begin{aligned}\text{Warrant AADT} &= 25,000 \text{ vpd} + (0.88 - 0.70) * [(13,800 \text{ vpd} - 25,000 \text{ vpd}) / (2.0 - 0.70)] \\ &= 23,450 \text{ vpd}\end{aligned}$$

Conclusion:

Since the actual AADT of 9,900 vpd < the Warrant AADT of 23,450 vpd, upgrading of the approach rail transition is NOT warranted.

THIS PAGE INTENTIONALLY LEFT BLANK

APPENDIX D2

EXISTING INFRA BRIDGE APPROACH RAIL TRANSITIONS AND CORRESPONDING SEVERITY INDICES

THIS PAGE LEFT INTENTIONALLY BLANK

Appendix D2

Existing INFTRA Bridge Approach Rail Transitions and Corresponding Severity Indices

TABLE OF CONTENTS

Figure Number	Figure Title	Page Number
Figure HD2.1	a.) Horizontal Rail Bridgerail on Safety Curb Approach Rail Transition b.) Vertical Bar Bridgerail on Safety Curb Approach Rail Transition	H-APP-D2-1
Figure HD2.2	c.) Single Layer/Double Layer Deep-Beam Bridgerail on Safety Curb Approach Rail Transition d.) Single Layer Deep-Beam Bridgerail on Participating Curb Approach Rail Transition	H-APP-D2-2
Figure HD2.3	e.) Double Layer Deep-Beam Bridgerail on Participating Curb Approach Rail Transition f.) Double Tube Bridgerail on Safety Curb Approach Rail Transition	H-APP-D2-3
Figure HD2.4	g.) Double Tube Bridgerail on Participating Approach Rail Transition h.) Single Tube Bridgerail on Participating Curb Approach Rail Transition	H-APP-D2-4

THIS PAGE INTENTIONALLY LEFT BLANK

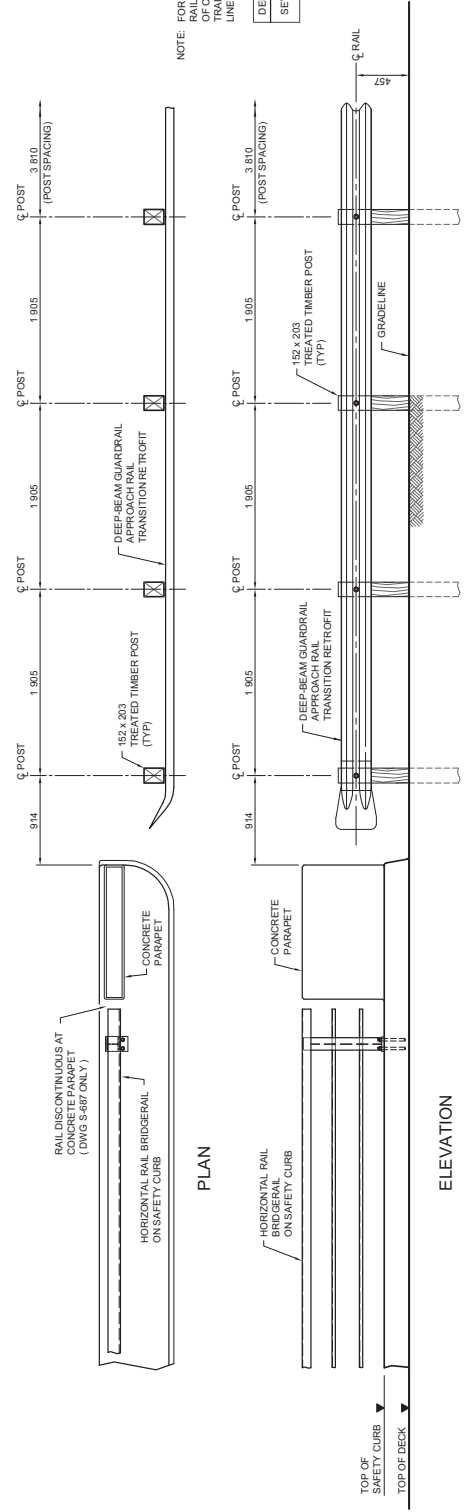

(a) HORIZONTAL RAIL BRIDGE RAIL ON SAFETY CURB APPROACH RAIL TRANSITION

(DETAILS SHOWN ARE BASED ON DWGS. S-687 AND S-974-69)

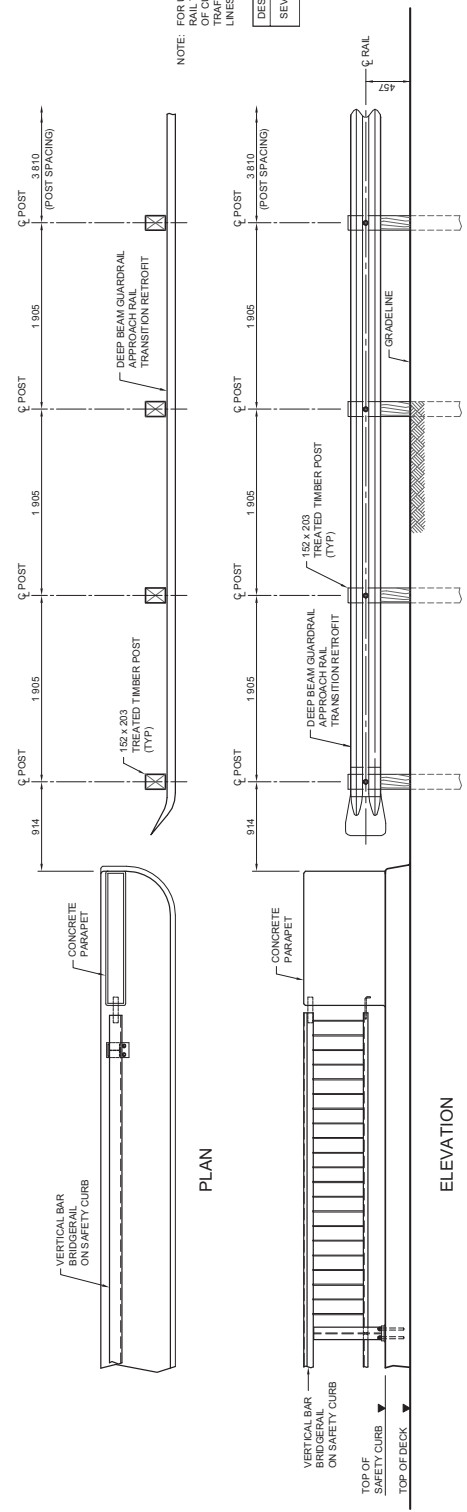

(b) VERTICAL BAR BRIDGE RAIL ON SAFETY CURB APPROACH RAIL TRANSITION

(DETAILS SHOWN ARE BASED ON DWGS. S-732 AND S-974-69)

NOTE: FOR UPSTREAM TRAFFIC, APPROACH RAIL TRANSITION LINES UP WITH FACE OF CURB (SHOWN); FOR DOWNSTREAM TRAFFIC, APPROACH RAIL TRANSITION LINES UP WITH FACE OF BRIDGE RAIL.

DESIGN SPEED (km/h)	50	60	80	100	110	120
SEVERITY INDEX	5.4m @ 2.2	5.8m @ 2.9	6.8m @ 4.0	8.5m @ 5.0	9.9m @ 6.0	11.4m @ 6.6

NOTE: FOR UPSTREAM TRAFFIC, APPROACH RAIL TRANSITION LINES UP WITH FACE OF CURB (SHOWN); FOR DOWNSTREAM TRAFFIC, APPROACH RAIL TRANSITION LINES UP WITH FACE OF BRIDGE RAIL.

DESIGN SPEED (km/h)	50	60	80	100	110	120
SEVERITY INDEX	5.4m @ 2.2	5.8m @ 2.8	6.8m @ 4.6	8.5m @ 5.6	9.9m @ 6.0	11.4m @ 6.6

EXISTING ALBERTA TRANSPORTATION APPROACH RAIL TRANSITIONS
FIGURE HD2.1

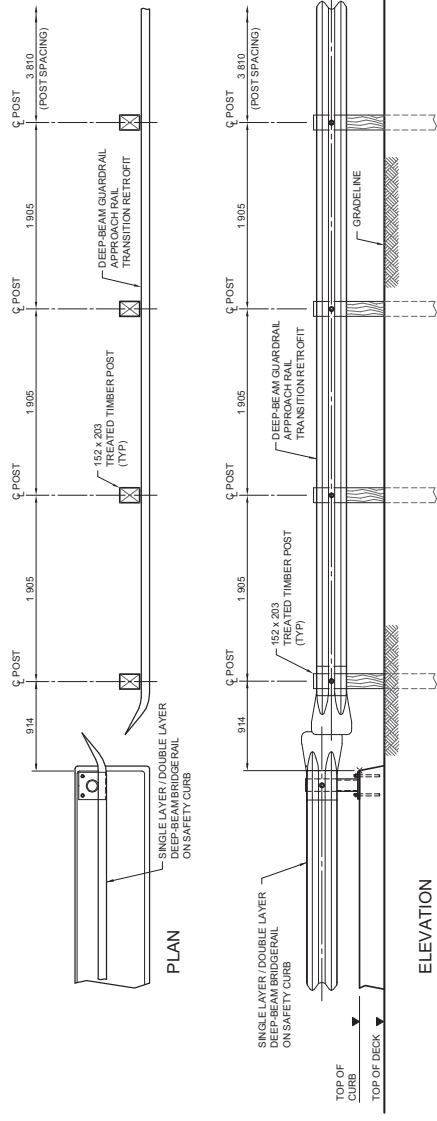

NOTE: FOR UPSTREAM TRAFFIC, APPROACH RAIL TRANSITION LINES UP WITH FACE OF CURB (SHOWN). FOR DOWNSTREAM TRAFFIC, APPROACH RAIL TRANSITION LINES UP WITH FACE OF BRIDGE RAIL.

DESIGN SPEED (km/h)	50	60	80	100	110	120
SEVERITY INDEX	5.4m @ 2.2	5.8m @ 2.6	6.9m @ 4.6	8.5m @ 5.6	9.9m @ 6.0	11.4m @ 6.6

(c) SINGLE LAYER / DOUBLE LAYER DEEP-BEAM BRIDGE RAIL ON SAFETY CURB APPROACH RAIL TRANSITION
(DETAILS SHOWN ARE BASED ON DWGS. S-459-483, S-675-689 AND S-674-689)

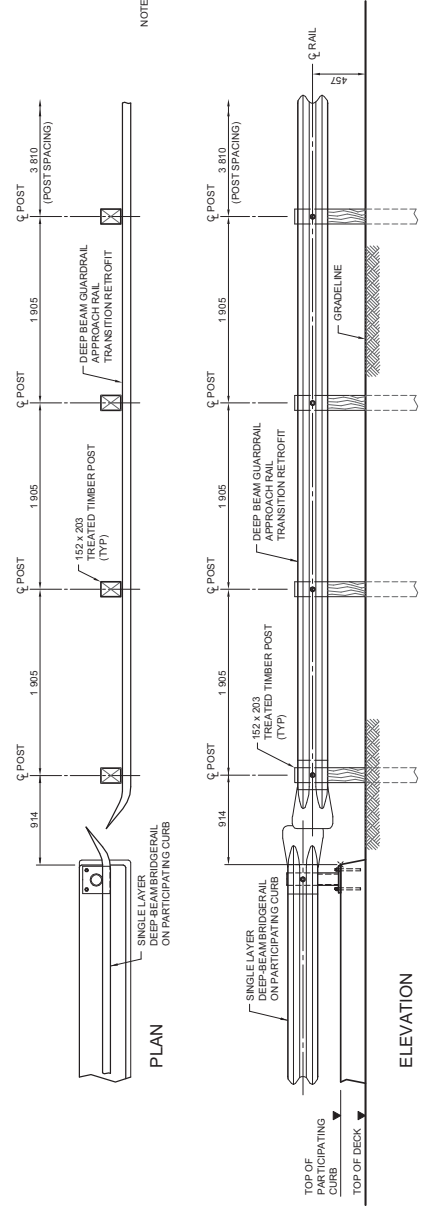

NOTE: FOR UPSTREAM TRAFFIC, APPROACH RAIL TRANSITION LINES UP WITH FACE OF CURB (SHOWN). FOR DOWNSTREAM TRAFFIC, APPROACH RAIL TRANSITION LINES UP WITH FACE OF BRIDGE RAIL.

DESIGN SPEED (km/h)	50	60	80	100	110	120
SEVERITY INDEX	2.4m @ 2.2	2.8m @ 2.6	3.9m @ 4.6	5.5m @ 5.6	6.8m @ 6.0	8.4m @ 6.6

(d) SINGLE LAYER DEEP-BEAM BRIDGE RAIL ON PARTICIPATING CURB APPROACH RAIL TRANSITION
(DETAILS SHOWN ARE BASED ON DWGS. S-459-483, S-675-689 AND S-674-689)

EXISTING ALBERTA TRANSPORTATION APPROACH RAIL TRANSITIONS
FIGURE HD2.2

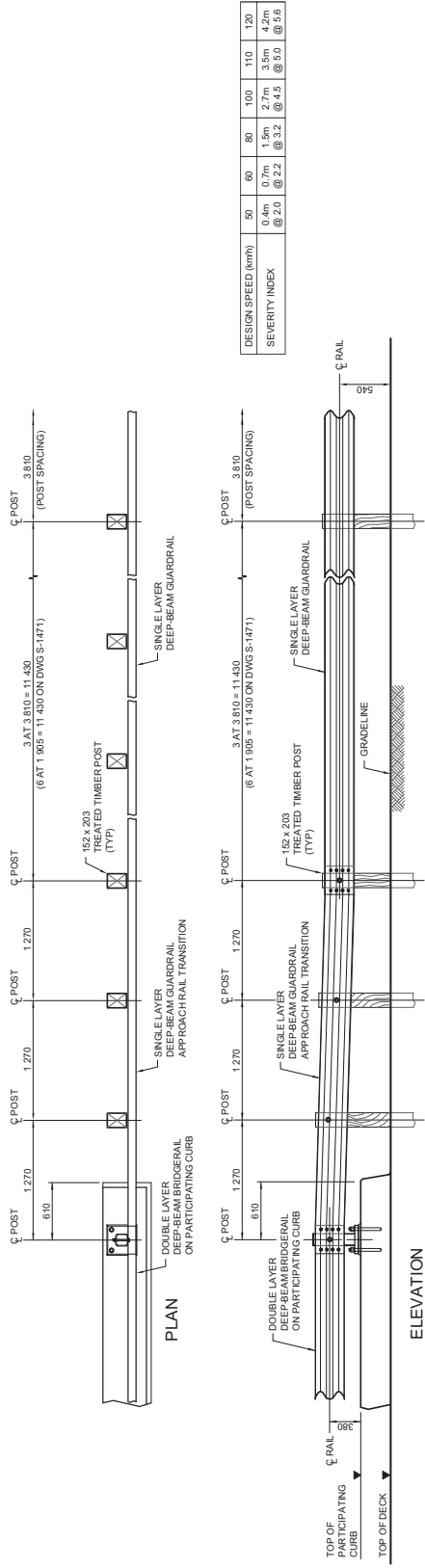

(e) DOUBLE LAYER DEEP-BEAM BRIDGERAIL ON PARTICIPATING CURB APPROACH RAIL TRANSITION

(DETAILS SHOWN ARE BASED ON DWGS. S-1402 AND S-1403)

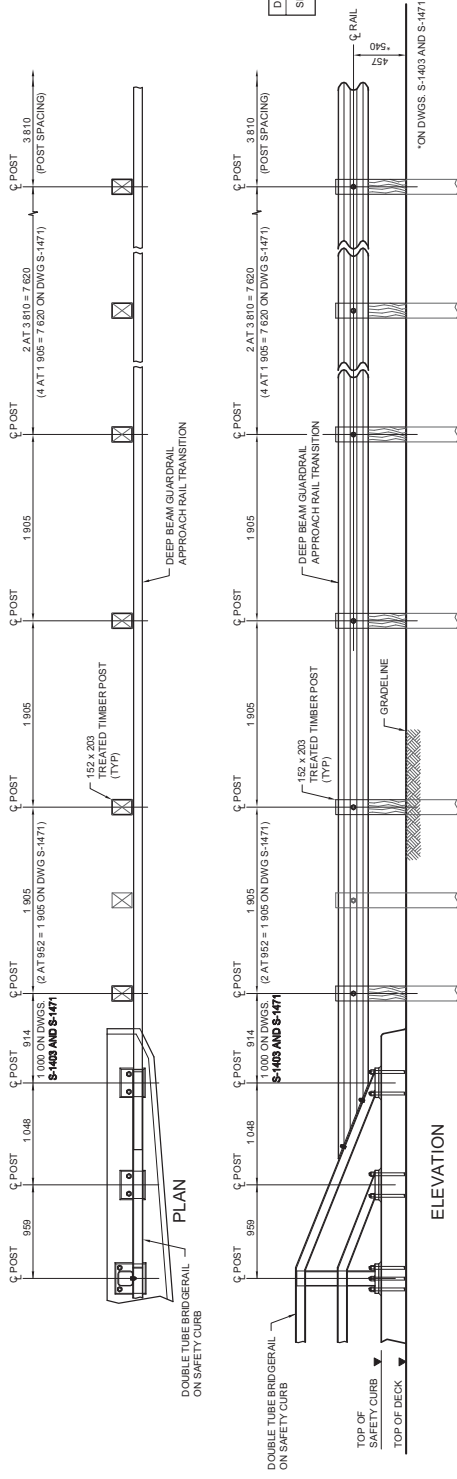

(f) DOUBLE TUBE BRIDGERAIL ON SAFETY CURB APPROACH RAIL TRANSITION

(DETAILS SHOWN ARE BASED ON DWGS. S-906/49 AND S-974/69)

EXISTING ALBERTA TRANSPORTATION APPROACH RAIL TRANSITIONS

FIGURE HD2.3

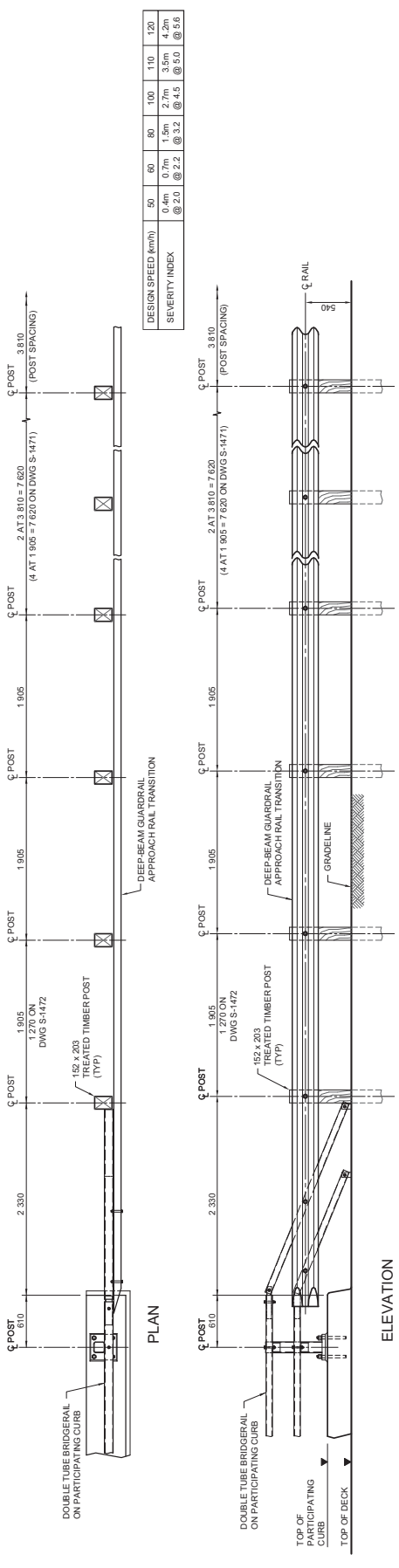

(g) DOUBLE TUBE BRIDGE RAIL ON PARTICIPATING CURB APPROACH RAIL TRANSITION
 (DETAILS SHOWN ARE BASED ON DWGS. S-1402 AND S-1403)

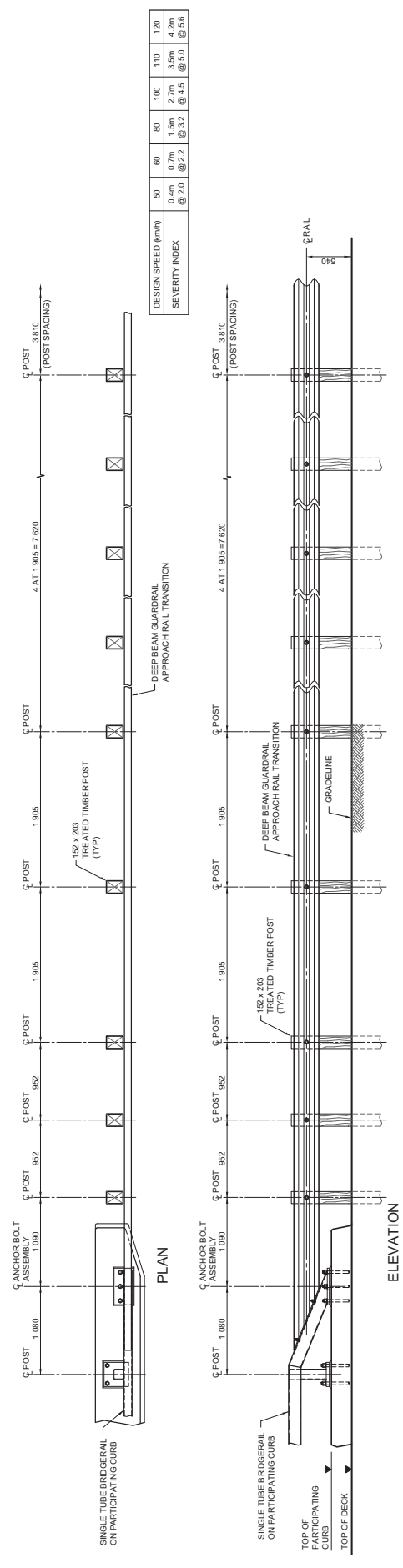

(h) SINGLE TUBE BRIDGE RAIL ON PARTICIPATING CURB APPROACH RAIL TRANSITION
 (DETAILS SHOWN ARE BASED ON DWGS. S-1019-06 AND S-1471)

EXISTING ALBERTA TRANSPORTATION APPROACH RAIL TRANSITIONS
FIGURE HD2.4

APPENDIX D3

INFTRA STANDARD DRAWINGS FOR UPGRADING OF EXISTING BRIDGE APPROACH RAIL TRANSITIONS

THIS PAGE LEFT INTENTIONALLY BLANK

Appendix D3

INFTRA Standard Drawings for Upgrading of Existing Bridge Approach Rail Transitions

TABLE OF CONTENTS

Dwg. No.	Drawing Title	Page Number
S-1711-07	Approach Rail Transition Upgrade Vertical Bar / Horizontal Rail Bridgerail Undivided Highway – Sheet 1	H-APP-D3-1
S-1712-07	Approach Rail Transition Upgrade Vertical Bar / Horizontal Rail Bridgerail Undivided Highway – Sheet 2	H-APP-D3-2
S-1713-07	Approach Rail Transition Upgrade Vertical Bar / Horizontal Rail Bridgerail Divided Highway – Sheet 1	H-APP-D3-3
S-1714-07	Approach Rail Transition Upgrade Vertical Bar / Horizontal Rail Bridgerail Divided Highway – Sheet 2	H-APP-D3-4
S-1715-07	Approach Rail Transition Upgrade Vertical Bar / Horizontal Rail Bridgerail Divided Highway – Sheet 3	H-APP-D3-5
S-1716-07	Approach Rail Transition Upgrade 850 mm Double Tube Bridgerail Sheet 1	H-APP-D3-6
S-1717-07	Approach Rail Transition Upgrade 850 mm Double Tube Bridgerail - Sheet 2	H-APP-D3-7
S-1718-07	Approach Rail Transition Upgrade 850 mm Double Tube Bridgerail - Sheet 3	H-APP-D3-8
S-1719-07	Approach Rail Transition Upgrade 850 mm Double Tube Bridgerail - Sheet 4	H-APP-D3-9
S-1720-07	Deep Beam (W-Beam) Bridgerail And Approach Rail Transition Upgrade Details	H-APP-D3-10

THIS PAGE INTENTIONALLY LEFT BLANK

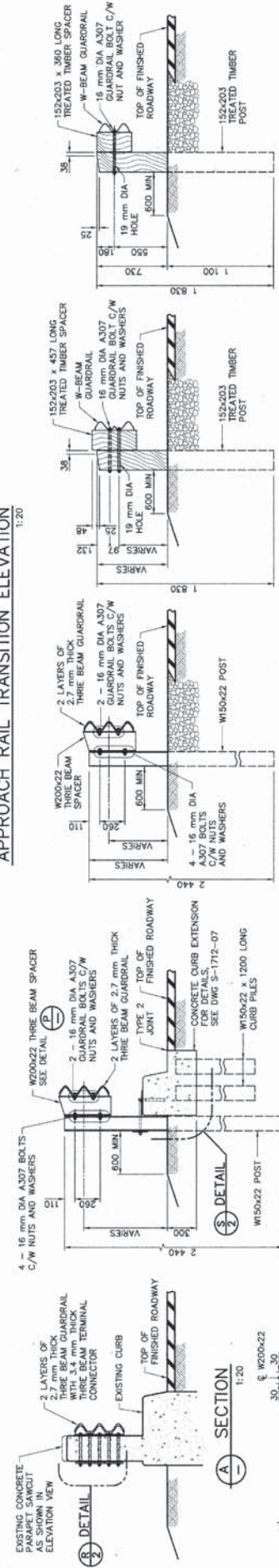
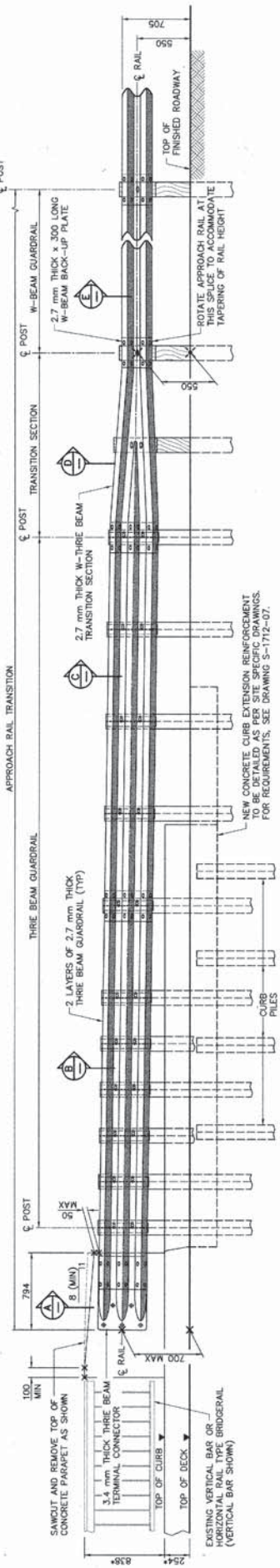
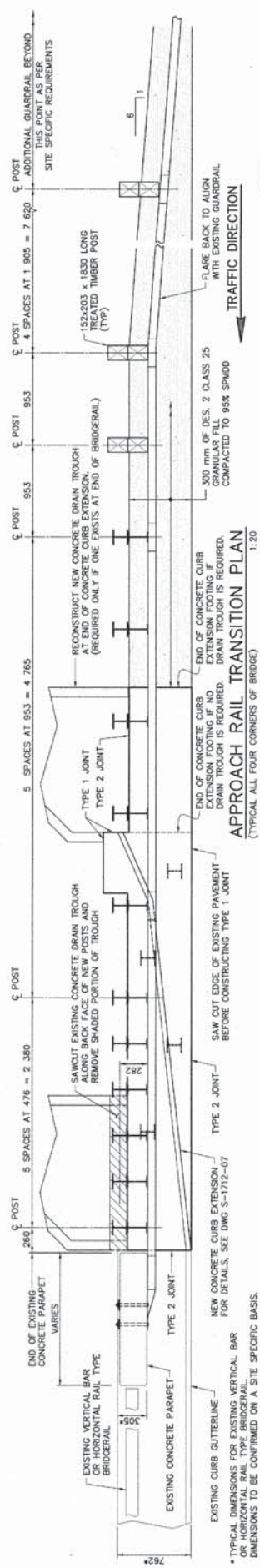

SECTION A 1:20

SECTION B 1:20

SECTION C 1:20

SECTION D 1:20

SECTION E 1:20

NOTE: TYPICAL FOR ALL POSTS BEHIND CONCRETE CURB EXTENSION

WORK THESE DRAWINGS TOGETHER: S-1711-07 AND S-1712-07

RECOMMENDED BRIDGE CONSTRUCTION

APPROVED BY: *[Signature]* DATE: 2007-04-03

DESIGNED BY: *[Signature]* DATE: 14-06-2007

CHECKED BY: *[Signature]* DATE: 04-04-2007

DESIGNER: ENGINEER ALBERTA PROFESSIONAL SOCIETY

DRAWER: ENGINEER ALBERTA PROFESSIONAL SOCIETY

PERMIT TO PRACTICE: UMA ENGINEERING LTD. Signature: *[Signature]* Date: 04-04-2007 PERMIT NUMBER: P-329 The Association of Professional Engineers, Geologists and Geophysicists of Alberta

Albera INFRASTRUCTURE AND TRANSPORTATION

APPROACH RAIL TRANSITION UPGRADE VERT. BAR / HORIZ. RAIL BRIDGERAIL UNDIVIDED HIGHWAY - SHEET 1

NO.	REV.	DATE	BY	DESCRIPTION
1	1	2007-04-03	SR	ISSUED

A: SHEET CODE: 2007-04-03 1 of 2 S-1711-07

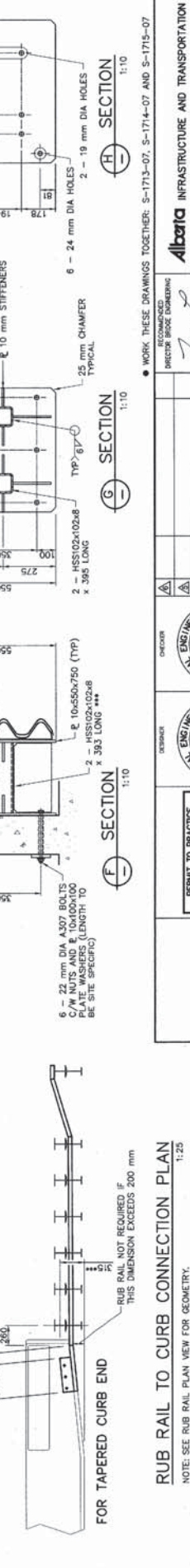
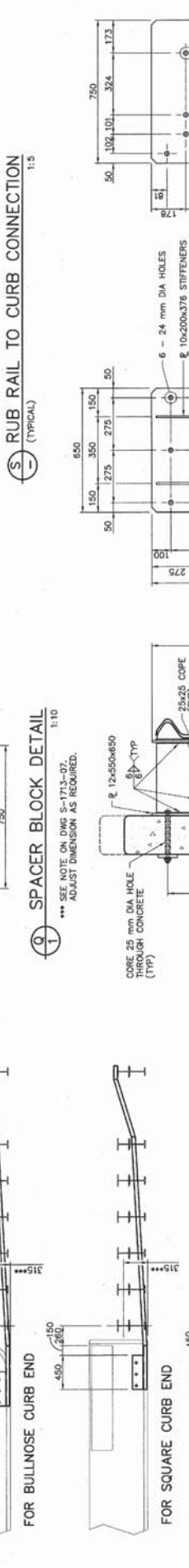
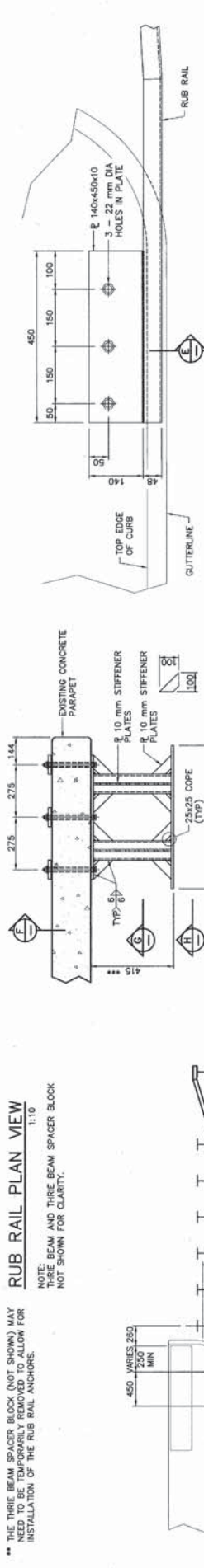
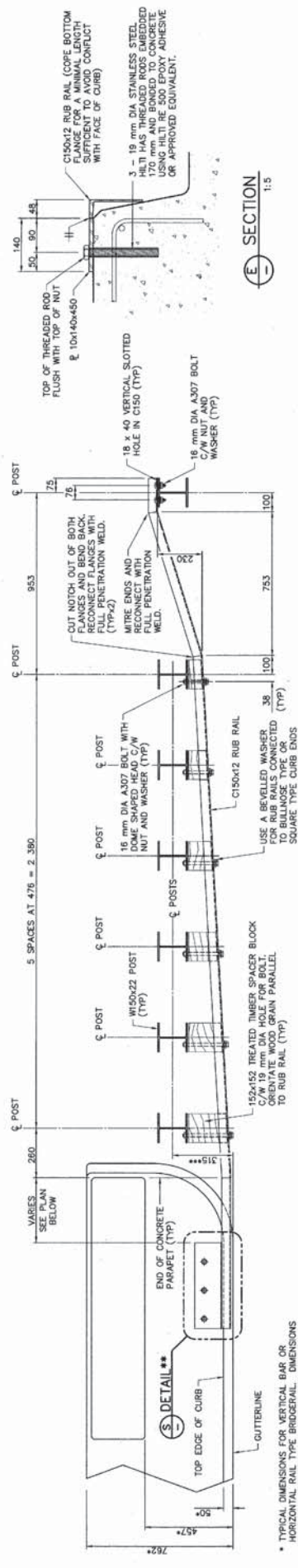

UMA AECOM		ENGINEER ALBERTA PROFESSIONAL SOCIETY OF ALBERTA REG. NO. 10000	ENGINEER ALBERTA PROFESSIONAL SOCIETY OF ALBERTA REG. NO. 10000	RECOMMENDED DIRECTOR OF HIGHWAYS DATE: 2007-04-02 BY: BML/2/2/07
PERMIT TO PRACTICE UMA ENGINEERING LTD. 10000-100th Street, Suite 100 Edmonton, Alberta T5A 0K1 PERMIT NUMBER: P329 The Association of Professional Engineers, Geologists and Geophysicists of Alberta		APPROVED 10-2007 (REVISED) DATE: 2007-04-02 BY: BML/2/2/07	APPROVED 10-2007 (REVISED) DATE: 2007-04-02 BY: BML/2/2/07	APPROVED 10-2007 (REVISED) DATE: 2007-04-02 BY: BML/2/2/07

APPROACH RAIL TRANSITION UPGRADE
VERT. BAR / HORIZ. RAIL BRIDGERAIL
DIVIDED HIGHWAY - SHEET 2

WORK THESE DRAWINGS TOGETHER: S-1713-07, S-1714-07 AND S-1715-07

Albarta INFRASTRUCTURE AND TRANSPORTATION

APPROACH RAIL TRANSITION UPGRADE
 VERT. BAR / HORIZ. RAIL BRIDGERAIL
 DIVIDED HIGHWAY - SHEET 2

DATE: 2007-04-02
 SHEET: S-1714-07

APPENDIX D3

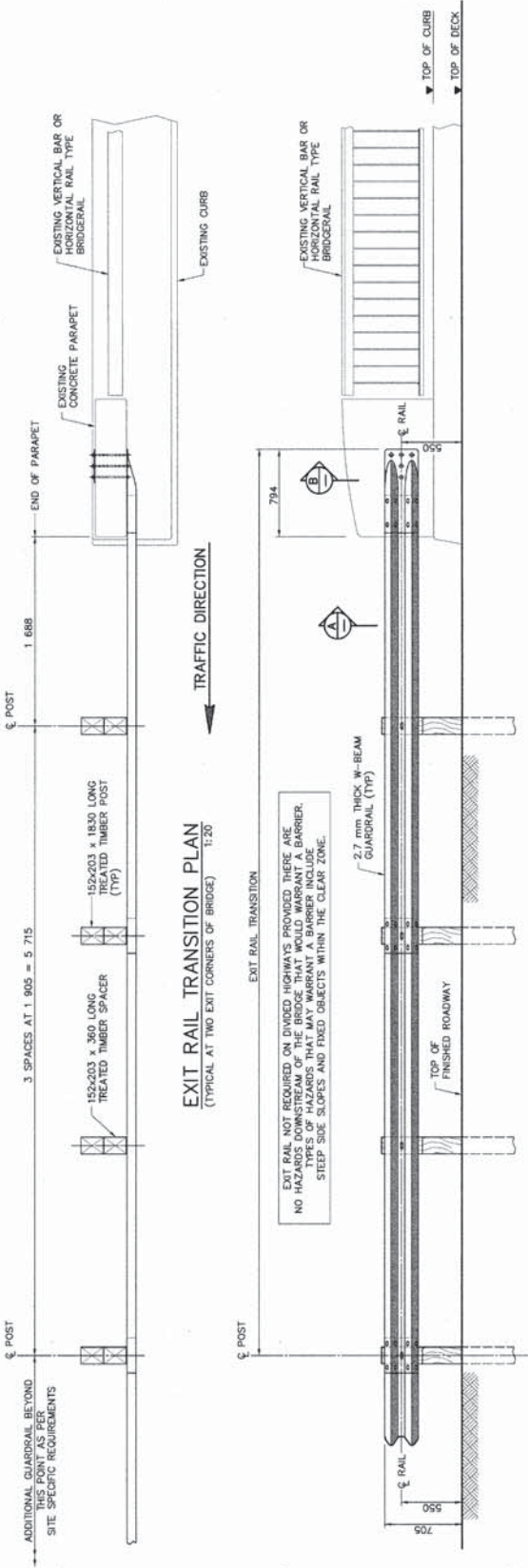

EXIT RAIL TRANSITION ELEVATION
1:20

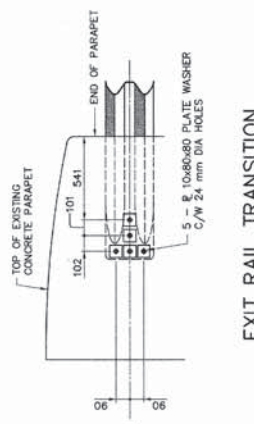

EXIT RAIL TRANSITION ANCHORAGE
(BACK FACE OF EXISTING CONCRETE PARAPET SHOWN) 1:15

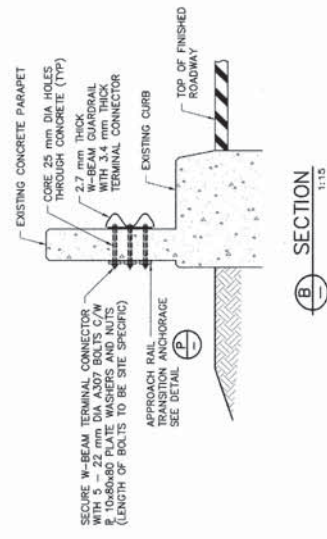

SECTION B
1:15

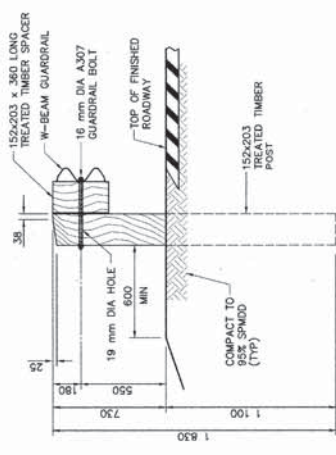

SECTION A
1:15

• WORK THESE DRAWINGS TOGETHER: S-1713-07, S-1714-07 AND S-1715-07

DESIGNED BY	APPROVED BY	DATE	REV	DATE
REVIEWED BY	DATE	REV	DATE	REV

UMA | AECOM
PERMIT TO PRACTICE
 ENGINEER ALBERTA
 PROFESSIONAL ENGINEER
 PERMIT NUMBER: P.329
 The Association of Professional Engineers, Geologists and Geophysicists of Alberta

Alberta INFRASTRUCTURE AND TRANSPORTATION APPROACH RAIL TRANSITION UPGRADE VERT. BAR / HORIZ. RAIL BRIDGERAIL DIVIDED HIGHWAY - SHEET 3	2007-04-03 2007-04-03 2007-04-03 2007-04-03	S-1715-07 S-1715-07 S-1715-07 S-1715-07
--	--	--

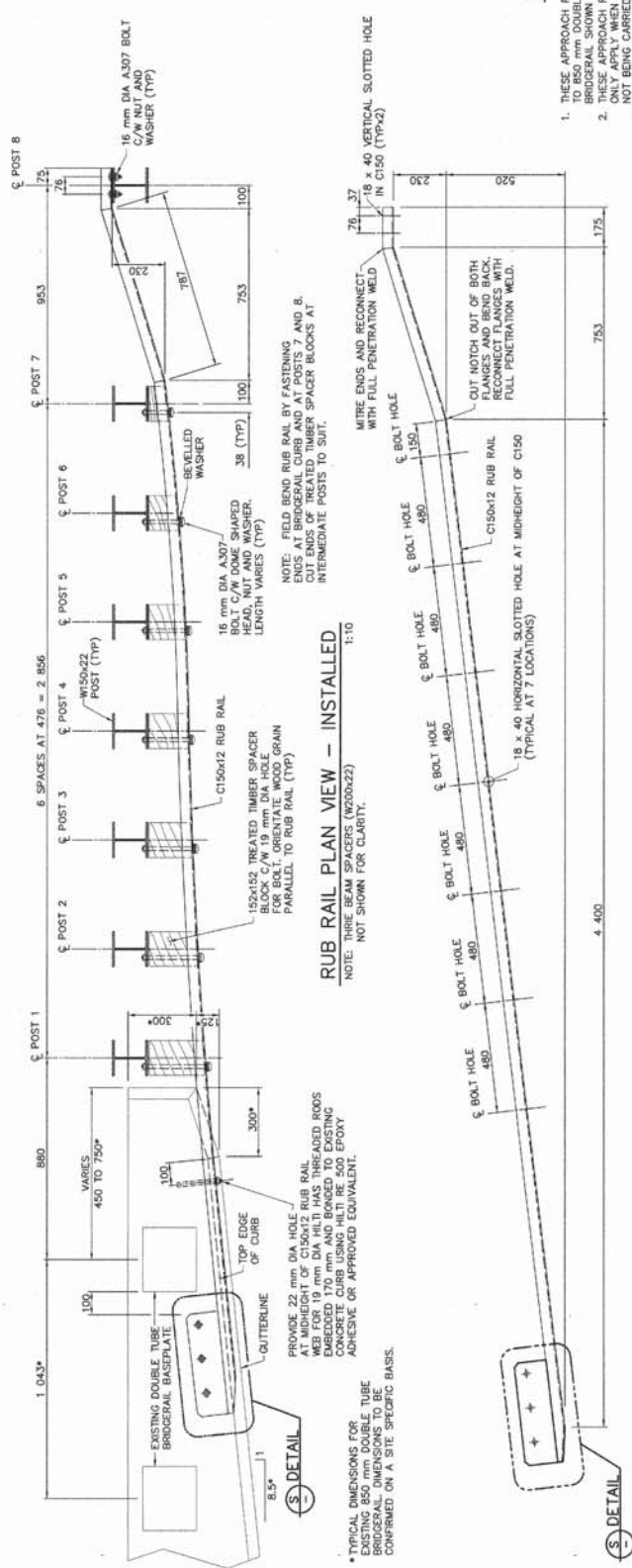

RUB RAIL PLAN VIEW - INSTALLED
1:10

RUB RAIL PLAN VIEW - FABRICATED
1:10

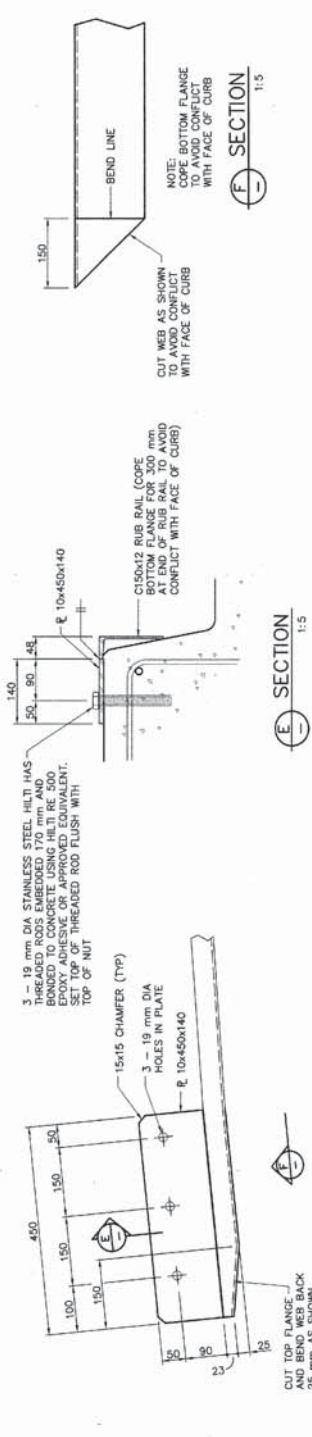

RUB RAIL/CURB CONNECTION
1:5

GENERAL NOTES

1. THESE APPROACH RAIL TRANSITION UPGRADE DRAWINGS APPLY TO 850 mm DOUBLE TUBE BRIDGERAILS SIMILAR TO THE BRIDGERAIL SHOWN ON DWG S-1716-07.
2. THESE APPROACH RAIL TRANSITION UPGRADE DRAWINGS ARE FOR THE BRIDGERAIL UPGRADE OF THE BRIDGERAIL NOT BEING CARRIED OUT.
3. ALL DIMENSIONS ARE IN MILLIMETRES UNLESS NOTED OTHERWISE.

FABRICATION

1. APPROACH RAIL TRANSITION SHALL CONFORM TO THE CURRENT REQUIREMENTS OF THE SPECIFICATIONS FOR BRIDGE CONSTRUCTION SECTION 4.02.01.
2. ALL QUADRANT STRUCTURAL SHAPES SHALL CONFORM TO CSA C40.21 GRADE 300W OR ASTM A36.
3. ALL BOLTS SHALL CONFORM TO ASTM A325 UNLESS NOTED OTHERWISE.
4. ALL W-BEAM AND THREE BEAM GUARDRAIL (INCLUDING THREE BEAM TERMINAL CONNECTOR AND W-BEAM TRANSITION SECTION) SHALL CONFORM TO THE CURRENT REQUIREMENTS OF THE SPECIFICATIONS FOR BRIDGE CONSTRUCTION SECTION 4.02.01.
5. TIMBER POSTS AND SPACERS SHALL BE COAST DOUGLAS FIR OR PACIFIC COAST HEMLOCK CONFORMING TO THE STRESS GRADE "SELECT STRUCTURAL POSTS AND TIMBERS" (ALGA PARAGRAPH 1.31 g).
6. ALL WELDING SHALL CONFORM TO CURRENT AWS SPECIFICATION D1.1.
7. ALL STEEL SHALL BE GALVANNEAL OR GALVANIZED AFTER FABRICATION IN ACCORDANCE WITH CSA G184 UNLESS NOTED OTHERWISE.

ERECTION

1. LINE AND ELEVATION OF BARRIER SHALL BE SET BY INSTRUMENT.
2. ALL POSTS SHALL BE VERTICAL.
3. ALL RAIL SECTIONS SHALL BE LAPPED IN THE DIRECTION OF TRAFFIC OR DAMAGED IN THE FIELD.
4. SHALL BE TOUCHED UP WITH TWO COATS OF ZINC RICH PAINT.

WORK THESE DRAWINGS TOGETHER: S-1716-07, S-1717-07, S-1718-07 AND S-1719-07

DATE: 2007-04-02	BY: A.M.C.	DATE: 2007-04-02	BY: A.M.C.
DATE: 2007-04-02	BY: A.M.C.	DATE: 2007-04-02	BY: A.M.C.

