

APPENDIX A

SEVERITY INDICES

THIS PAGE INTENTIONALLY LEFT BLANK

Appendix A Severity Indices

TABLE OF CONTENTS

Table Number	Title	Page Number
HA.1	Sideslopes	H-APP-A-3
HA.2	Sideslopes – Vertical with and without water present	H-APP-A-13
HA.3	Backslopes	H-APP-A-15
HA.4	Parallel Ditches	H-APP-A-21
HA.5	Approach Slopes – Negative (down)	H-APP-A-25
HA.6	Approach Slopes – Vertical Drop with and without Water Present	H-APP-A-37
HA.7	Approach Slopes – Positive (up)	H-APP-A-38
HA.8	Traffic Barriers	H-APP-A-45
HA.9	Fixed Objects - Rounded	H-APP-A-49
HA.9	Fixed Objects – Rectangular	H-APP-A-49
HA.9	Fixed Objects - Trees	H-APP-A-51
HA.9	Fixed Objects - Utility Poles (Wooden)	H-APP-A-51
HA.9	Fixed Objects - Breakaway Supports	H-APP-A-51
HA.10	Culverts	H-APP-A-52

THIS PAGE INTENTIONALLY LEFT BLANK

Severity Indices

Severity Indices (SI) are numbers from zero to ten used to categorize collisions by the probability of property damage, personal injury, or a fatality, or any combination of these possible outcome.

An SI value of zero (0) represents a collision with no significant property damage or injury, while an SI value of ten (10) corresponds to a collision with a 100% probability of a fatality.

As the severity of the collision increases, the costs associated with the collisions also increase.

Figure HA.1 illustrates the general relationship between collision costs and the severity indices, as provided in AASHTO's Roadside Design Guide, 1988.

FIGURE HA.1 Collision Cost versus Severity Index

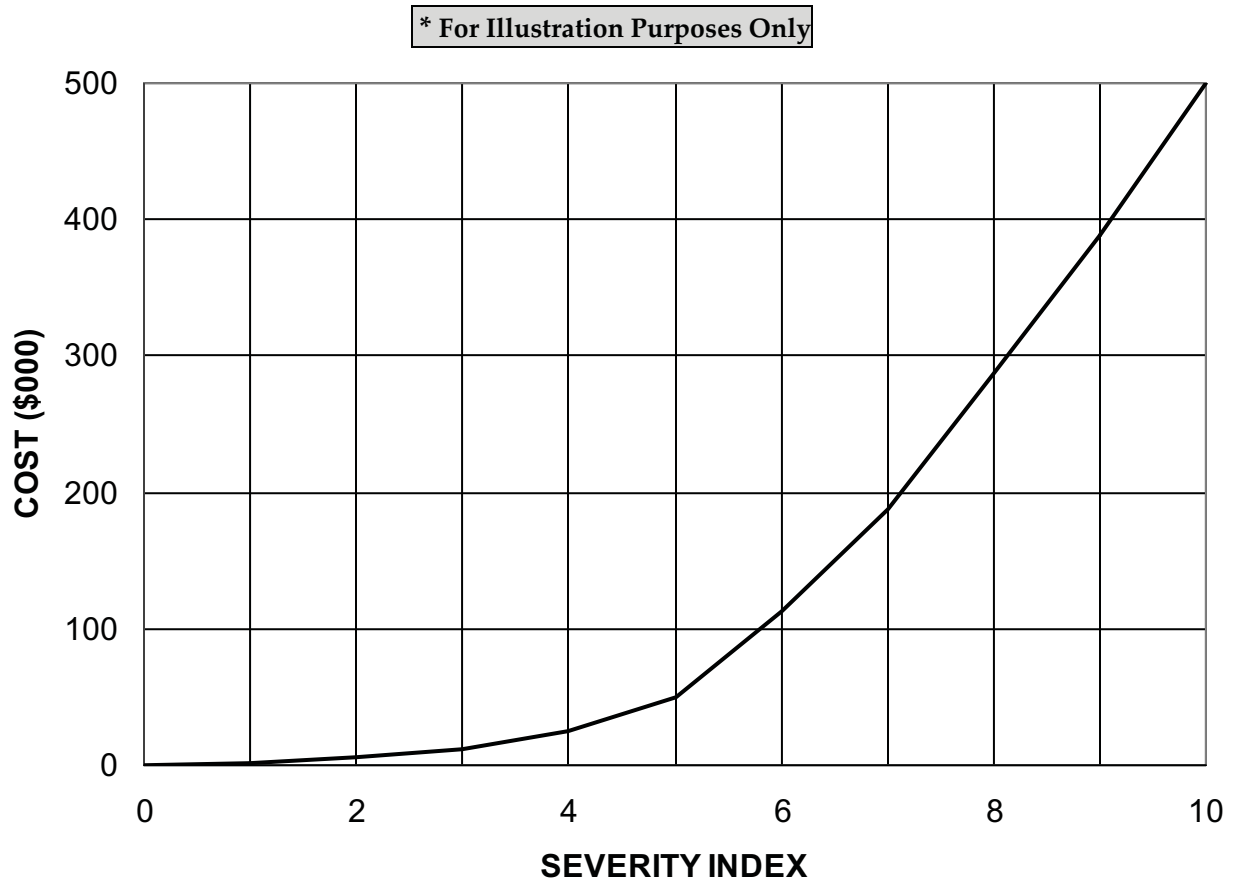

Values based on 1989 dollar value
Source: AASHTO's Roadside Design Guide, 1988

* Use updated dollar values in Table HC1.7 on page H-APP-C1-7.

The following sections provide severity indices (SI) for a variety of roadside features including:

- sideslopes
- vertical sideslopes with or without water
- backslopes
- parallel ditches
- approach slopes
- traffic barriers
- end treatments
- crash cushions
- fixed objects
- culverts.

The SI values are adopted from the 1996 AASHTO's Roadside Design Guide, and supplemented with the SI values from the 1991 FHWA Supplemental Information for use with the Roadside Program.

For additional guidance on the use of the severity indices, refer to the latest edition of AASHTO's Roadside Design Guide.

Where the values are not available from the AASHTO's Roadside Design Guide, such as the values for a 5 to 1 sideslope, the values are interpolated between the values immediately in advance of and after the required sideslope.

SI information for High tension cable systems are currently not available. Designer should based the SI values on the in-service experience of the system in similar application, in consultation with staff from INFTRA.

The surface condition in the SI tables refers to the ground condition approaching the hazard. There are five types of surface conditions:

A	Smooth and firm all seasons
B	Smooth but subject to deep rutting by errant vehicles half of the year
C	Shallow gullies (100 to 200 mm deep), scattered small boulders (under 225-mm projections), scattered small trees (diameters 75 to 100 mm), or structurally substantial woody brush. Features spaced so that nearly all encroaching vehicles will encounter them.
D	Medium gullies (approximately 250 mm deep), boulders or riprap (projecting approximately 300 mm), or medium trees (diameters 175 to 225 mm). Features spaced so that they will be encountered by all encroaching vehicles. It is assumed that density of features will preclude deep penetration of roadside. If this assumption is not valid, SIs for high, steep slopes may be considerably higher than values shown.
E	Deep gullies (over 0.5 m deep), large boulders or heavy riprap (over 450-mm projecting), large trees (diameters over 350 mm). Features spaced so that they will be encountered by all encroaching vehicles. It is assumed that density of features will preclude deep penetration of roadside. If this assumption is not valid, SIs for high, steep slopes may be considerably higher than values shown.

**TABLE HA.1 Suggested Severity Indices
Sideslopes**

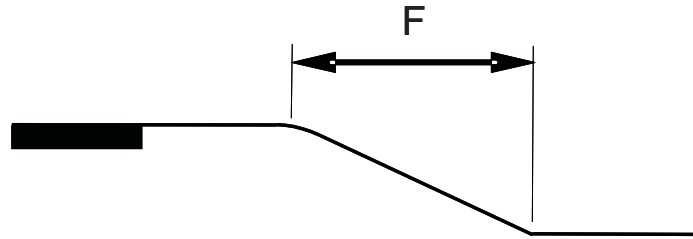

Object Type and Characteristics			Object Surface (*)	Severity Index							
Slope (H:V)	Height (m)	Surface Condition		Design Speed - km/h							
				50	60	70	80	90	100	110	120
Sideslope ∞:1	0.15	A	F	0.1	0.2	0.2	0.3	0.4	0.5	0.7	0.8
		B	F	0.3	0.4	0.4	0.5	0.6	0.8	1.0	1.1
		C	F	0.4	0.6	0.8	1.0	1.1	1.3	1.5	1.8
		D	F	2.8	3.3	3.8	4.3	4.8	5.4	5.9	6.4
		E	F	3.2	3.6	4.0	4.5	5.1	5.7	6.3	7.0
Sideslope 10:1	0.15	A	F	0.2	0.3	0.5	0.6	0.7	0.9	1.1	1.2
		B	F	0.4	0.5	0.7	0.8	0.9	1.1	1.3	1.6
		C	F	0.7	0.9	1.1	1.3	1.4	1.6	1.9	2.2
		D	F	2.8	3.3	3.8	4.3	4.8	5.4	5.9	6.4
		E	F	3.2	3.6	4.0	4.5	5.1	5.7	6.3	7.0
	≥0.3	A	F	0.4	0.5	0.7	0.8	1.0	1.2	1.4	1.5
		B	F	0.6	0.7	0.9	1.0	1.2	1.4	1.6	1.9
		C	F	0.9	1.1	1.3	1.5	1.7	1.9	2.2	2.5
		D	F	2.8	3.3	3.8	4.3	4.8	5.4	5.9	6.4
		E	F	3.2	3.6	4.0	4.5	5.1	5.7	6.3	7.0
Sideslope 8:1	0.15	A	F	0.3	0.4	0.6	0.7	0.8	1.0	1.2	1.3
		B	F	0.5	0.6	0.8	0.9	1.0	1.2	1.4	1.7
		C	F	0.8	1.0	1.2	1.4	1.5	1.7	2.0	2.3
		D	F	2.8	3.3	3.8	4.3	4.8	5.4	5.9	6.4
		E	F	3.2	3.6	4.0	4.5	5.1	5.7	6.3	7.0

*S = Approach Side, C = Corner, F= Traffic Face, A = S, C, and F

**TABLE HA.1 Suggested Severity Indices
Sideslopes (continued)**

Object Type and Characteristics			Object Surface (*)	Severity Index							
Slope (H:V)	Height (m)	Surface Condition		Design Speed - km/h							
				50	60	70	80	90	100	110	120
Sideslope 8:1 (cont.)	≥0.3	A	F	0.4	0.6	0.8	1.0	1.2	1.4	1.6	1.9
		B	F	0.6	0.8	1.0	1.2	1.4	1.6	1.9	2.2
		C	F	0.9	1.2	1.4	1.7	1.9	2.1	2.5	2.9
		D	F	2.8	3.3	3.8	4.3	4.8	5.4	5.9	6.4
		E	F	3.2	3.6	4.0	4.5	5.1	5.7	6.3	7.0
Sideslope 6:1	0.15	A	F	0.5	0.8	1.0	1.3	1.5	1.7	1.9	2.0
		B	F	0.7	1.0	1.2	1.5	1.7	1.9	2.1	2.2
		C	F	1.1	1.4	1.7	2.0	2.2	2.4	2.6	2.9
		D	F	2.9	3.4	3.9	4.4	4.9	5.5	5.9	6.3
		E	F	3.3	3.7	4.1	4.6	5.2	5.8	6.4	6.9
	≥0.3	A	F	0.5	0.8	1.0	1.3	1.6	1.9	2.1	2.2
		B	F	0.7	1.0	1.2	1.5	1.8	2.1	2.3	2.6
		C	F	1.1	1.4	1.7	2.0	2.3	2.6	2.9	3.2
		D	F	3.0	3.8	4.0	4.5	5.0	5.6	6.0	6.4
		E	F	3.4	3.8	4.2	4.7	5.3	5.9	6.5	7.0
Sideslope 5:1	0.15	A	F	0.5	0.8	1.0	1.2	1.4	1.6	1.8	2.0
		B	F	0.7	1.0	1.2	1.4	1.6	1.8	2.1	2.3
		C	F	1.1	1.4	1.6	1.9	2.1	2.3	2.6	3.0
		D	F	3.0	3.5	4.0	4.5	5.0	5.6	6.0	6.4
		E	F	3.4	3.8	4.2	4.7	5.3	5.9	6.5	7.0
	≥0.3	A	F	0.9	1.1	1.3	1.6	1.8	2.1	2.3	2.4
		B	F	1.1	1.3	1.5	1.8	2.0	2.3	2.5	2.8
		C	F	1.4	1.7	2.0	2.3	2.5	2.8	3.1	3.4
		D	F	3.1	3.7	4.0	4.5	5.0	5.6	6.0	6.4
		E	F	3.5	3.9	4.3	4.8	5.4	6.0	6.6	7.1

*S = Approach Side, C = Corner, F= Traffic Face, A = S, C, and F

**TABLE HA.1 Suggested Severity Indices
Sideslopes (continued)**

Object Type and Characteristics			Object Surface	Severity Index							
Slope (H:V)	Height (m)	Surface Condition		Design Speed - km/h							
				50	60	70	80	90	100	110	120
Sideslope 4:1	0.15	A	F	0.5	0.7	0.9	1.1	1.3	1.5	1.7	2.0
		B	F	0.7	0.9	1.1	1.3	1.5	1.7	2.0	2.3
		C	F	1.0	1.3	1.5	1.8	2.0	2.2	2.6	3.0
		D	F	3.0	3.5	4.0	4.5	5.0	5.6	6.0	6.4
		E	F	3.4	3.8	4.2	4.7	5.3	5.9	6.5	7.0
	0.3	A	F	1.2	1.4	1.6	1.8	2.0	2.2	2.4	2.5
		B	F	1.4	1.6	1.8	2.0	2.2	2.4	2.6	2.9
		C	F	1.7	2.0	2.2	2.5	2.7	2.9	3.2	3.5
		D	F	3.2	3.6	4.0	4.5	5.0	5.6	6.0	6.4
		E	F	3.5	3.9	4.3	4.8	5.4	6.0	6.6	7.1
	≥2	A	F	1.3	1.6	1.8	2.1	2.3	2.5	2.7	2.8
		B	F	1.5	1.8	2.0	2.3	2.5	2.7	2.9	3.2
		C	F	1.9	2.2	2.5	2.8	3.0	3.2	3.5	3.8
		D	F	3.2	3.6	4.0	4.5	5.0	5.6	6.0	6.4
		E	F	3.5	3.9	4.3	4.8	5.4	6.0	6.6	7.1
Sideslope 3:1	0.15	A	F	0.7	0.9	1.1	1.3	1.5	1.8	2.0	2.3
		B	F	0.9	1.1	1.3	1.5	1.7	2.0	2.3	2.6
		C	F	1.2	1.5	1.7	2.0	2.2	2.5	2.9	3.3
		D	F	3.2	3.6	4.0	4.5	5.0	5.6	6.0	6.4
		E	F	3.5	3.9	4.3	4.8	5.4	6.0	6.6	7.1
	0.3	A	F	1.6	1.8	2.0	2.2	2.4	2.6	2.8	2.9
		B	F	1.8	2.0	2.2	2.4	2.6	2.8	3.0	3.3
		C	F	2.1	2.4	2.6	2.9	3.1	3.3	3.6	3.9
		D	F	3.3	3.7	4.1	4.6	5.1	5.7	6.1	6.5
		E	F	3.6	4.0	4.4	4.9	5.5	6.1	6.7	7.2

*S = Approach Side, C = Corner, F= Traffic Face, A = S, C, and F

**TABLE HA.1 Suggested Severity Indices
Sideslopes (continued)**

Object Type and Characteristics			Object Surface	Severity Index							
Slope (H:V)	Height (m)	Surface Condition		Design Speed - km/h							
				50	60	70	80	90	100	110	120
Sideslope 3:1 (cont.)	2	A	F	2.0	2.3	2.5	2.8	3.0	3.3	3.5	3.6
		B	F	2.2	2.5	2.7	3.0	3.2	3.5	3.7	4.0
		C	F	2.6	2.9	3.2	3.5	3.7	4.0	4.3	4.6
		D	F	3.4	3.8	4.2	4.7	5.2	5.8	6.2	6.6
		E	F	3.7	4.1	4.5	5.0	5.6	6.2	6.8	7.3
	4	A	F	2.0	2.3	2.6	2.9	3.1	3.4	3.6	3.9
		B	F	2.2	2.5	2.8	3.1	3.3	3.6	3.9	4.2
		C	F	2.5	2.8	3.2	3.6	3.8	4.1	4.5	4.9
		D	F	3.5	3.9	4.3	4.8	5.3	5.9	6.3	6.7
		E	F	3.8	4.2	4.6	5.1	5.7	6.3	6.9	7.4
	6	A	F	2.0	2.3	2.6	2.9	3.1	3.5	3.7	4.0
		B	F	2.2	2.5	2.8	3.1	3.3	3.7	4.0	4.3
		C	F	2.5	2.8	3.2	3.6	3.8	4.2	4.6	5.0
		D	F	3.5	3.9	4.3	4.8	5.3	5.9	6.3	6.7
		E	F	3.8	4.2	4.6	5.1	5.7	6.3	6.9	7.4
	8	A	F	2.0	2.3	2.6	2.9	3.2	3.5	3.8	4.1
		B	F	2.2	2.5	2.8	3.1	3.4	3.7	4.0	4.3
		C	F	2.5	2.8	3.2	3.6	3.9	4.2	4.6	5.0
		D	F	3.5	3.9	4.3	4.8	5.3	5.9	6.3	6.7
		E	F	3.8	4.2	4.6	5.1	5.7	6.3	6.9	7.4
≥10	A	F	2.0	2.3	2.6	2.9	3.2	3.5	3.9	4.3	
	B	F	2.2	2.5	2.8	3.1	3.4	3.7	4.1	4.5	
	C	F	2.5	2.8	3.2	3.6	3.9	4.3	4.7	5.1	
	D	F	3.5	3.9	4.3	4.8	5.3	5.9	6.3	6.7	
	E	F	3.8	4.2	4.3	5.1	5.7	6.3	6.9	7.4	

*S = Approach Side, C = Corner, F= Traffic Face, A = S, C, and F

**TABLE HA.1 Suggested Severity Indices
Sideslopes (continued)**

Object Type and Characteristics			Object Surface	Severity Index								
Slope (H:V)	Height (m)	Surface Condition		Design Speed - km/h								
				50	60	70	80	90	100	110	120	
Sideslope 2:1	0.15	A	F	0.9	1.2	1.5	1.8	2.0	2.3	2.6	2.9	
		B	F	1.1	1.4	1.7	2.0	2.2	2.5	2.9	3.3	
		C	F	1.4	1.7	2.1	2.5	2.7	3.1	3.5	3.9	
		D	F	3.3	3.7	4.1	4.6	5.1	5.7	6.1	6.5	
		E	F	3.6	4.0	4.4	4.9	5.5	6.1	6.7	7.2	
	0.3	A	F	2.1	2.3	2.5	2.7	2.9	3.1	3.3	3.6	3.6
		B	F	2.3	2.5	2.7	2.9	3.1	3.3	3.6	3.9	3.9
		C	F	2.6	2.9	3.1	3.4	3.6	3.8	4.2	4.6	4.6
		D	F	3.4	3.8	4.2	4.7	5.2	5.8	6.2	6.6	6.6
		E	F	3.7	4.1	4.5	5.0	5.6	6.2	6.8	7.3	7.3
	2	A	F	2.9	3.2	3.5	3.8	4.0	4.3	4.5	4.8	4.8
		B	F	2.3	2.9	3.4	4.0	4.2	4.5	4.8	5.1	5.1
		C	F	2.6	3.2	3.9	4.5	4.7	5.0	5.4	5.8	5.8
		D	F	3.5	3.9	4.3	4.8	5.3	5.9	6.3	6.7	6.7
		E	F	3.8	4.2	4.6	5.1	5.7	6.3	6.9	7.4	7.4
	4	A	F	3.1	3.4	3.8	4.2	4.4	4.6	4.8	5.1	5.1
		B	F	2.5	3.1	3.8	4.4	4.6	4.8	5.1	5.4	5.4
		C	F	2.8	3.5	4.2	4.9	5.1	5.3	5.7	6.1	6.1
		D	F	3.8	4.1	4.5	4.9	5.4	6.0	6.4	6.8	6.8
		E	F	3.9	4.3	4.7	5.2	5.8	6.4	7.0	7.5	7.5
	6	A	F	3.3	3.6	3.9	4.3	4.5	4.7	4.9	5.2	5.2
		B	F	3.2	3.6	4.1	4.5	4.7	4.9	5.2	5.5	5.5
		C	F	2.9	4.0	4.5	4.9	5.2	5.4	6.1	6.2	6.2
		D	F	3.8	4.1	4.5	4.9	5.4	6.0	6.4	6.8	6.8
		E	F	3.9	4.3	4.7	5.2	5.8	6.4	7.0	7.5	7.5

*S = Approach Side, C = Corner, F= Traffic Face, A = S, C, and F

**TABLE HA.1 Suggested Severity Indices
Sideslopes (continued)**

Object Type and Characteristics			Object Surface	Severity Index							
Slope (H:V)	Height (m)	Surface Condition		Design Speed - km/h							
				50	60	70	80	90	100	110	120
Sideslope 2:1 (cont.)	8	A	F	3.6	3.9	4.1	4.4	4.6	4.8	5.0	5.3
		B	F	3.8	4.1	4.3	4.6	4.8	5.0	5.3	5.6
		C	F	4.1	4.4	4.7	5.0	5.2	5.4	5.8	6.2
		D	F	3.8	4.1	4.5	4.9	5.4	6.0	6.4	6.8
		E	F	3.9	4.3	4.7	5.2	5.8	6.4	7.0	7.5
	10	A	F	4.1	4.3	4.5	4.7	4.9	5.2	5.4	5.5
		B	F	4.2	4.4	4.6	4.8	5.0	5.3	5.5	5.8
		C	F	4.4	4.7	4.9	5.2	5.4	5.7	6.0	6.3
		D	F	3.8	4.1	4.5	4.9	5.4	6.0	6.4	6.8
		E	F	3.9	4.3	4.7	5.2	5.8	6.4	7.0	7.5
	14	A	F	4.5	4.7	4.9	5.1	5.3	5.5	5.7	6.0
		B	F	4.6	4.8	5.0	5.2	5.4	5.6	5.9	6.2
		C	F	4.7	5.0	5.2	5.5	5.7	5.9	6.3	6.7
		D	F	3.8	4.1	4.5	4.9	5.4	6.0	6.4	6.8
		E	F	3.9	4.3	4.7	5.2	5.8	6.4	7.0	7.5
	18	A	F	4.8	5.0	5.2	5.4	5.6	5.8	6.0	6.3
		B	F	4.9	5.1	5.3	5.5	5.7	5.9	6.1	6.4
		C	F	4.9	5.2	5.4	5.7	5.9	6.1	6.4	6.7
		D	F	3.8	4.1	4.5	4.9	5.4	6.0	6.4	6.8
		E	F	3.9	4.3	4.7	5.2	5.8	6.4	7.0	7.5
	22	A	F	4.9	5.1	5.3	5.5	5.7	5.9	6.1	6.4
		B	F	5.0	5.2	5.4	5.6	5.8	6.0	6.2	6.5
		C	F	5.1	5.3	5.5	5.7	5.9	6.2	6.5	6.8
		D	F	3.8	4.1	4.5	4.9	5.4	6.0	6.4	6.8
		E	F	3.9	4.3	4.7	5.2	5.8	6.4	7.0	7.5

*S = Approach Side, C = Corner, F= Traffic Face, A = S, C, and F

**TABLE HA.1 Suggested Severity Indices
Sideslopes (continued)**

Object Type and Characteristics			Object Surface	Severity Index							
Slope (H:V)	Height (m)	Surface Condition		Design Speed - km/h							
				50	60	70	80	90	100	110	120
Sideslope 2:1 (cont.)	26	A	F	4.8	5.1	5.3	5.6	5.8	6.1	6.3	6.4
		B	F	4.9	5.2	5.4	5.7	5.9	6.2	6.4	6.5
		C	F	5.0	5.3	5.5	5.8	6.0	6.3	6.6	6.9
		D	F	3.8	4.1	4.5	4.9	5.4	6.0	6.4	6.8
		E	F	3.9	4.3	4.7	5.2	5.8	6.4	7.0	7.5
	30	A	F	4.8	5.1	5.3	5.6	5.9	6.2	6.4	6.5
		B	F	4.9	5.2	5.4	5.7	6.0	6.3	6.5	6.6
		C	F	5.0	5.3	5.5	5.8	6.1	6.4	6.6	6.9
		D	F	3.8	4.1	4.5	4.9	5.4	6.0	6.4	6.8
		E	F	3.9	4.3	4.7	5.2	5.8	6.4	7.0	7.5
	≥34	A	F	4.8	5.1	5.3	5.6	5.9	6.2	6.4	6.7
		B	F	4.9	5.3	5.4	5.7	6.0	6.3	6.5	6.8
		C	F	5.0	5.3	5.5	5.8	6.1	6.4	6.6	6.9
		D	F	3.8	4.1	4.5	4.9	5.4	6.0	6.6	7.3
		E	F	3.9	4.3	4.7	5.2	5.8	6.4	7.0	7.5
Sideslope 1½:1	0.15	A	F	0.9	1.3	1.7	2.2	2.4	2.7	3.0	3.3
		B	F	1.1	1.5	1.9	2.4	2.6	2.9	3.3	3.7
		C	F	1.4	1.9	2.4	2.9	3.1	3.5	3.9	4.3
		D	F	3.3	3.8	4.3	4.8	5.3	5.9	6.3	6.7
		E	F	3.7	4.1	4.5	5.0	5.6	6.2	6.8	7.3
	0.3	A	F	2.4	2.6	2.8	3.0	3.2	3.5	3.7	4.0
		B	F	2.6	2.8	3.0	3.2	3.4	3.7	4.0	4.3
		C	F	2.9	3.2	3.4	3.7	3.9	4.2	4.6	5.0
		D	F	3.3	3.8	4.3	4.8	5.3	5.9	6.4	6.9
		E	F	3.7	4.1	4.5	5.0	5.6	6.2	6.9	7.6

*S = Approach Side, C = Corner, F= Traffic Face, A = S, C, and F

**TABLE HA.1 Suggested Severity Indices
Sideslopes (continued)**

Object Type and Characteristics			Object Surface	Severity Index							
Slope (H:V)	Height (m)	Surface Condition		Design Speed - km/h							
				50	60	70	80	90	100	110	120
Sideslope 1½:1 (cont.)	2	A	F	3.3	3.6	3.9	4.2	4.5	4.8	5.0	5.3
		B	F	3.2	3.5	3.7	4.0	4.4	4.8	5.2	5.6
		C	F	3.6	3.9	4.2	4.5	4.9	5.3	5.8	6.3
		D	F	3.4	3.9	4.4	4.9	5.4	6.0	6.5	7.0
		E	F	3.7	4.1	4.5	5.0	5.6	6.2	6.9	7.6
	4	A	F	3.8	4.1	4.4	4.7	4.9	5.2	5.4	5.7
		B	F	3.8	4.1	4.5	4.9	5.4	5.9	6.2	6.5
		C	F	4.8	5.0	5.2	5.4	5.8	6.3	6.8	7.3
		D	F	3.8	4.1	4.5	4.9	5.4	6.0	6.5	7.0
		E	F	3.8	4.2	4.6	5.1	5.7	6.3	7.0	7.7
	6	A	F	4.1	4.4	4.7	5.0	5.2	5.5	5.7	6.0
		B	F	4.7	4.4	4.7	5.5	5.9	6.3	6.6	7.0
		C	F	5.3	5.4	5.7	5.9	6.2	6.7	7.2	7.6
		D	F	3.9	4.2	4.6	5.0	5.5	6.0	6.6	7.2
		E	F	3.9	4.3	4.7	5.1	5.8	6.4	7.1	7.8
	8	A	F	4.3	4.6	4.9	5.2	5.4	5.7	5.9	6.2
		B	F	5.5	5.6	5.8	5.9	6.3	6.6	7.0	7.4
		C	F	5.7	5.9	6.1	6.3	6.6	7.0	7.5	8.0
		D	F	3.9	4.2	4.6	5.0	5.5	6.0	6.6	7.3
		E	F	3.9	4.3	4.7	5.2	5.8	6.4	7.1	7.8
10	A	F	4.9	5.2	5.4	5.7	6.0	6.3	6.6	6.9	
	B	F	6.4	6.5	6.7	6.8	7.2	7.6	7.8	8.1	
	C	F	6.8	6.9	7.1	7.2	7.6	8.0	8.2	8.5	
	D	F	4.0	4.3	4.7	5.1	5.6	6.1	6.7	7.4	
	E	F	4.0	4.4	4.8	5.3	5.9	6.5	7.2	7.9	

*S = Approach Side, C = Corner, F= Traffic Face, A = S, C, and F

**TABLE HA.1 Suggested Severity Indices
Sideslopes (continued)**

Object Type and Characteristics			Object Surface	Severity Index							
Slope (H:V)	Height (m)	Surface Condition		Design Speed - km/h							
				50	60	70	80	90	100	110	120
Sideslope 1½:1 (cont.)	14	A	F	5.4	5.7	5.9	6.2	6.6	6.9	7.2	7.5
		B	F	7.1	7.2	7.4	7.5	7.9	8.2	8.5	8.8
		C	F	7.5	7.6	7.8	7.9	8.2	8.5	8.8	9.1
		D	F	4.0	4.3	4.7	5.1	5.6	6.1	6.7	7.4
		E	F	4.0	4.4	4.8	5.3	5.9	6.5	7.2	7.9
	18	A	F	5.8	6.1	6.4	6.7	7.1	7.4	7.7	8.0
		B	F	7.6	7.7	7.9	8.0	8.4	8.7	9.0	9.3
		C	F	7.9	8.0	8.2	8.3	8.6	8.9	9.2	9.5
		D	F	4.0	4.3	4.7	5.1	5.6	6.1	6.7	7.4
		E	F	4.0	4.4	4.8	5.3	5.9	6.5	7.2	7.9
	22	A	F	6.2	6.5	6.8	7.1	7.4	7.7	8.0	8.3
		B	F	7.7	7.9	8.1	8.3	8.6	8.9	9.1	9.2
		C	F	8.0	8.2	8.4	8.6	8.8	9.1	9.3	9.4
		D	F	4.0	4.3	4.7	5.1	5.6	6.1	6.7	7.4
		E	F	4.2	4.5	4.9	5.3	5.9	6.5	7.2	7.9
	26	A	F	6.3	6.6	6.9	7.2	7.5	7.8	8.1	8.4
		B	F	7.9	8.1	8.3	8.5	8.8	9.1	9.3	9.6
		C	F	8.0	8.3	8.5	8.8	9.0	9.2	9.4	9.7
		D	F	4.1	4.4	4.8	5.2	5.6	6.1	6.7	7.4
		E	F	4.2	4.5	4.9	5.3	5.9	6.5	7.2	7.9
30	A	F	6.6	6.9	7.1	7.4	7.7	8.0	8.3	8.6	
	B	F	7.8	8.1	8.3	8.6	8.8	9.1	9.4	9.7	
	C	F	8.0	8.3	8.5	8.8	9.0	9.2	9.4	9.7	
	D	F	4.1	4.4	4.8	5.2	5.5	6.1	6.7	7.4	
	E	F	4.2	4.5	4.9	5.3	5.9	6.5	7.2	7.9	

*S = Approach Side, C = Corner, F= Traffic Face, A = S, C, and F

TABLE HA.1 Suggested Severity Indices
Sideslopes (continued)

Object Type and Characteristics			Object Surface	Severity Index							
Slope (H:V)	Height (m)	Surface Condition		Design Speed - km/h							
				50	60	70	80	90	100	110	120
Sideslope 1½:1 (cont.)	34	A	F	6.8	7.1	7.3	7.6	7.8	8.1	8.4	8.7
		B	F	7.9	8.2	8.4	8.7	8.9	9.2	9.4	9.7
		C	F	8.1	8.4	8.6	8.9	9.0	9.2	9.4	9.7
		D	F	4.1	4.4	4.8	5.2	5.6	6.1	6.7	7.4
		E	F	4.2	4.5	4.9	5.3	5.9	6.5	7.2	7.9
	≥38	A	F	6.9	7.2	7.4	7.7	7.9	8.2	8.5	8.8
		B	F	8.0	8.3	8.5	8.8	9.0	9.3	9.5	9.8
		C	F	8.3	8.5	8.7	8.9	9.1	9.3	9.5	9.8
		D	F	4.1	4.4	4.8	5.2	5.6	6.1	6.7	7.4
		E	F	4.2	4.5	4.9	5.3	5.9	6.5	7.2	7.9

*S = Approach Side, C = Corner, F= Traffic Face, A = S, C, and F

**TABLE HA.2 Suggested Severity Indices
Sideslopes – Vertical with and without water present**

Object Type and Characteristics			Object Surface (*)	Severity Index, SI							
Slope (H:V)	Height (m)	Water Depth (m)		Height(m)							
				50	60	70	80	90	100	110	120
Sideslope Vertical	0.0	0	F	0.1	0.2	0.2	0.3	0.4	0.5	0.7	0.8
		1	F	2.6	2.7	2.9	3.0	3.2	3.4	3.6	3.7
		2	F	4.4	4.7	4.9	5.2	5.4	5.7	5.9	6.2
		4	F	6.2	6.4	6.6	6.8	7.0	7.2	7.4	7.7
		≥6	F	7.9	8.1	8.3	8.5	8.7	8.8	9.0	9.1
	0.3	0	F	2.6	2.9	3.1	3.4	3.6	3.9	4.1	4.4
		1	F	3.2	3.4	3.6	3.8	4.0	4.2	4.4	4.7
		2	F	4.6	4.9	5.2	5.5	5.9	6.2	6.6	7.0
		4	F	6.3	6.6	6.9	7.2	7.4	7.7	7.9	8.2
		≥6	F	8.2	8.3	8.5	8.6	8.8	9.0	9.2	9.3
	2.0	0	F	3.8	4.1	4.3	4.6	4.8	5.1	5.3	5.6
		1	F	4.4	4.6	4.8	5.0	5.2	5.4	5.6	5.7
		2	F	6.7	6.8	7.0	7.1	7.3	7.5	7.7	7.8
		4	F	7.6	7.7	7.9	8.0	8.2	8.4	8.6	8.7
		≥6	F	8.4	8.5	8.7	8.8	9.0	9.2	9.4	9.5
	4.0	0	F	5.7	5.8	5.8	5.9	6.1	6.3	6.5	6.6
		1	F	5.7	5.9	6.1	6.3	6.5	6.7	6.9	7.0
		2	F	7.4	7.5	7.7	7.8	8.0	8.2	8.4	8.5
		4	F	8.0	8.1	8.3	8.4	8.6	8.8	9.0	9.1
		≥6	F	8.6	8.7	8.9	9.0	9.2	9.4	9.6	9.7
	6.0	0	F	6.6	6.7	6.8	6.9	7.0	7.2	7.4	7.5
		1	F	6.8	6.9	7.1	7.3	7.4	7.6	7.8	7.9
		2	F	7.8	7.9	8.1	8.2	8.4	8.6	8.8	8.9
		4	F	8.2	8.3	8.5	8.7	8.9	9.1	9.3	9.4
		≥6	F	8.7	8.8	9.0	9.1	9.3	9.5	9.7	9.8

*S = Approach Side, C = Corner, F= Traffic Face, A = S, C, and F

**TABLE HA.2 Suggested Severity Indices
Sideslopes – Vertical with and without water present (continued)**

Object Type and Characteristics			Object Surface (*)	Severity Index, SI							
Slope (H:V)	Height (m)	Water Depth (m)		Design Speed – km/h							
				50	60	70	80	90	100	110	120
Sideslope Vertical (cont.)	8.0	0	F	7.4	7.5	7.7	7.8	7.9	8.0	8.2	8.3
		1	F	7.8	7.9	8.1	8.2	8.3	8.4	8.6	8.7
		2	F	8.1	8.2	8.4	8.5	8.7	8.9	9.1	9.2
		4	F	8.3	8.5	8.7	8.9	9.1	9.3	9.5	9.6
		≥6	F	8.8	8.9	9.1	9.2	9.4	9.6	9.8	9.9
	10.0	0	F	8.6	8.8	9.0	9.2	9.2	9.2	9.3	9.3
		1	F	8.7	8.9	9.1	9.3	9.4	9.4	9.6	9.7
		2	F	9.2	9.3	9.3	9.4	9.5	9.6	9.8	9.9
		4	F	9.5	9.6	9.6	9.7	9.8	9.8	9.9	9.9
		≥6	F	9.7	9.8	9.8	9.9	10.0	10.0	10.0	10.0
	14.0	0	F	9.5	9.6	9.6	9.7	9.8	9.8	9.8	9.8
		1	F	9.6	9.7	9.7	9.8	9.8	9.8	9.9	9.9
		2	F	9.6	9.7	9.7	9.8	9.9	9.9	10.0	10.0
		4	F	9.8	9.9	9.9	10.0	10.0	10.0	10.0	10.0
		≥6	F	10.0	10.0	10.0	10.0	10.0	10.0	10.0	10.0
	18.0	0	F	9.9	9.9	9.9	9.9	9.9	9.9	10.0	10.0
		1	F	10.0	10.0	10.0	10.0	10.0	10.0	10.0	10.0
		2	F	10.0	10.0	10.0	10.0	10.0	10.0	10.0	10.0
		4	F	10.0	10.0	10.0	10.0	10.0	10.0	10.0	10.0
		≥6	F	10.0	10.0	10.0	10.0	10.0	10.0	10.0	10.0
	22.0	0	F	10.0	10.0	10.0	10.0	10.0	10.0	10.0	10.0
		1	F	10.0	10.0	10.0	10.0	10.0	10.0	10.0	10.0
		2	F	10.0	10.0	10.0	10.0	10.0	10.0	10.0	10.0
		4	F	10.0	10.0	10.0	10.0	10.0	10.0	10.0	10.0
		≥6	F	10.0	10.0	10.0	10.0	10.0	10.0	10.0	10.0

*S = Approach Side, C = Corner, F= Traffic Face, A = S, C, and F

**TABLE HA.3 Suggested Severity Indices
Backslopes**

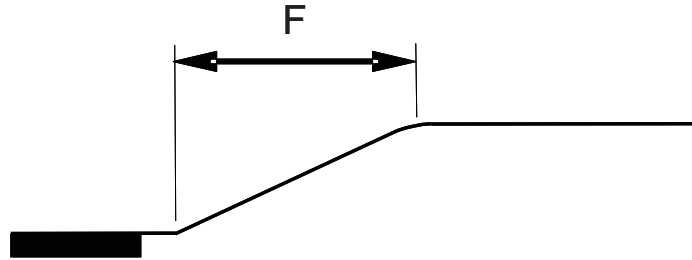

Object Type and Characteristics			Object Surface	Severity Index, SI							
Slope (H:V)	Height (m)	Surface Condition		Design Speed – km/h							
				50	60	70	80	90	100	110	120
Backslope 10:1	0.15	A	F	0.1	0.1	0.1	0.2	0.3	0.4	0.6	0.7
		B	F	0.2	0.3	0.3	0.4	0.5	0.7	0.9	1.0
		C	F	0.6	0.7	0.9	1.0	1.1	1.3	1.5	1.8
		D	F	2.8	3.3	3.8	4.3	4.8	5.4	5.9	6.4
		E	F	3.2	3.6	4.0	4.5	5.1	5.7	6.3	7.0
	≥0.3	A	F	0.1	0.1	0.1	0.2	0.3	0.3	0.5	0.6
		B	F	0.1	0.1	0.3	0.4	0.5	0.6	0.8	0.9
		C	F	0.6	0.7	0.9	1.0	1.1	1.3	1.5	1.8
		D	F	2.6	3.2	3.9	4.5	5.1	5.7	6.3	7.0
		E	F	3.2	3.6	4.0	4.5	5.1	5.7	6.3	7.0
Backslope 8:1	0.15	A	F	0.1	0.1	0.2	0.3	0.4	0.4	0.6	0.7
		B	F	0.1	0.2	0.4	0.5	0.6	0.7	0.9	1.0
		C	F	0.6	0.7	0.9	1.0	1.1	1.3	1.5	1.8
		D	F	2.8	3.3	3.8	4.3	4.8	5.4	5.9	6.4
		E	F	3.2	3.6	4.0	4.5	5.1	5.7	6.3	7.0
	≥0.3	A	F	0.1	0.1	0.1	0.2	0.3	0.3	0.5	0.6
		B	F	0.1	0.2	0.2	0.3	0.4	0.6	0.8	0.9
		C	F	0.6	0.7	0.9	1.0	1.1	1.3	1.5	1.8
		D	F	2.8	3.3	3.8	4.3	4.8	5.4	5.9	6.4
		E	F	3.2	3.6	4.0	4.5	5.1	5.7	6.3	7.0

*S = Approach Side, C = Corner, F= Traffic Face, A = S, C, and F

**TABLE HA.3 Suggested Severity Indices
Backslopes (continued)**

Object Type and Characteristics			Object Surface (*)	Severity Index, SI							
Slope (H:V)	Height (m)	Surface Condition		Design Speed – km/h							
				50	60	70	80	90	100	110	120
Backslope 6:1	0.15	A	F	0.1	0.1	0.1	0.2	0.3	0.3	0.5	0.6
		B	F	0.1	0.2	0.4	0.5	0.5	0.6	0.8	0.9
		C	F	0.6	0.7	0.9	1.0	1.1	1.3	1.5	1.8
		D	F	2.8	3.3	3.8	4.3	4.8	5.4	5.9	6.4
		E	F	3.2	3.6	4.0	4.5	5.1	5.7	6.3	7.0
	≥0.5	A	F	0.1	0.1	0.1	0.2	0.3	0.3	0.5	0.6
		B	F	0.1	0.2	0.4	0.5	0.5	0.6	0.8	0.9
		C	F	0.6	0.7	0.9	1.0	1.1	1.3	1.5	1.8
		D	F	2.8	3.3	3.8	4.3	4.8	5.4	5.9	6.4
		E	F	3.2	3.6	4.0	4.5	5.1	5.7	6.3	7.0
Backslope 4:1	≥0.15	A	F	0.1	0.1	0.3	0.4	0.5	0.6	0.8	0.9
		B	F	0.4	0.5	0.5	0.6	0.7	0.9	1.1	1.2
		C	F	0.7	0.8	1.0	1.1	1.3	1.4	1.6	1.7
		D	F	2.8	3.3	3.8	4.3	4.8	5.4	5.9	6.4
		E	F	3.2	3.6	4.0	4.5	5.1	5.7	6.3	7.0
Backslope 3:1	0.15	A	F	0.2	0.3	0.5	0.6	0.7	0.7	0.9	1.0
		B	F	0.4	0.5	0.7	0.8	0.9	1.1	1.3	1.4
		C	F	0.8	0.9	1.1	1.2	1.4	1.6	1.8	1.9
		D	F	2.8	3.3	3.8	4.3	4.8	5.4	5.9	6.4
		E	F	3.2	3.6	4.0	4.5	5.1	5.7	6.3	7.0
	≥1.0	A	F	0.3	0.4	0.6	0.7	0.9	1.2	1.3	1.4
		B	F	0.7	0.8	1.0	1.1	1.3	1.5	1.7	1.8
		C	F	1.3	1.4	1.6	1.7	1.9	2.1	2.3	2.4
		D	F	2.9	3.4	3.9	4.4	4.9	5.5	6.0	6.5
		E	F	3.2	3.6	4.0	4.5	5.1	5.7	6.3	7.0

*S = Approach Side, C = Corner, F= Traffic Face, A = S, C, and F

**TABLE HA.3 Suggested Severity Indices
Backslopes (continued)**

Object Type and Characteristics			Object Surface	Severity Index, SI							
Slope (H:V)	Height (m)	Surface Condition		Design Speed – km/h							
				50	60	70	80	90	100	110	120
Backslope 2:1	0.15	A	F	0.4	0.5	0.7	0.8	1.0	1.2	1.4	1.7
		B	F	0.7	0.8	1.0	1.1	1.3	1.5	1.7	2.0
		C	F	1.0	1.1	1.3	1.4	1.6	1.9	2.2	2.5
		D	F	2.9	3.4	3.9	4.4	4.9	5.5	6.0	6.5
		E	F	3.2	3.6	4.0	4.5	5.1	5.7	6.3	7.0
	0.3	A	F	0.5	0.6	0.8	0.9	1.1	1.3	1.6	1.9
		B	F	0.9	1.0	1.2	1.3	1.4	1.6	1.9	2.2
		C	F	1.4	1.5	1.7	1.8	1.9	2.1	2.3	2.6
		D	F	3.0	3.5	4.0	4.5	5.0	5.6	6.1	6.6
		E	F	3.3	3.7	4.1	4.6	5.2	5.8	6.4	7.1
	0.6	A	F	0.7	0.8	1.0	1.1	1.3	1.5	1.8	2.1
		B	F	1.1	1.2	1.4	1.5	1.7	1.9	2.1	2.4
		C	F	1.9	2.0	2.2	2.3	2.4	2.6	2.8	3.1
		D	F	3.0	3.5	4.0	4.5	5.0	5.6	6.1	6.6
		E	F	3.3	3.7	4.1	4.6	5.2	5.8	6.4	7.1
	≥1.2	A	F	0.8	0.9	1.1	1.2	1.5	1.8	2.1	2.4
		B	F	1.2	1.3	1.5	1.6	1.8	2.1	2.3	2.6
		C	F	2.0	2.1	2.3	2.4	2.5	2.7	2.9	3.2
		D	F	3.0	3.5	4.0	4.5	5.0	5.6	6.1	6.6
		E	F	3.3	3.7	4.1	4.6	5.2	5.8	6.4	7.1
Backslope 1½:1	0.15	A	F	0.3	0.6	0.8	1.1	1.4	1.8	2.2	2.6
		B	F	0.6	0.9	1.1	1.4	1.7	2.1	2.5	2.9
		C	F	0.9	1.2	1.4	1.7	2.1	2.5	3.0	3.5
		D	F	2.9	3.4	3.9	4.4	4.9	5.5	6.0	6.5
		E	F	3.2	3.6	4.0	4.5	5.1	5.7	6.3	7.0

*S = Approach Side, C = Corner, F= Traffic Face, A = S, C, and F

**TABLE HA.3 Suggested Severity Indices
Backslopes (continued)**

Object Type and Characteristics			Object Surface	Severity Index, SI							
Slope (H:V)	Height (m)	Surface Condition		Design Speed – km-h							
				50	60	70	80	90	100	110	120
Backslope 1 ½ :1 (cont.)	≥0.3	A	F	0.5	0.8	1.0	1.3	1.6	2.0	2.6	3.1
		B	F	0.9	1.2	1.4	1.7	1.9	2.3	2.9	3.4
		C	F	1.4	1.7	1.9	2.2	2.4	2.8	3.3	3.8
		D	F	3.0	3.5	4.0	4.5	5.0	5.6	6.1	6.6
		E	F	3.3	3.7	4.1	4.6	5.2	5.8	6.4	7.1
	0.6	A	F	0.9	1.1	1.3	1.5	1.8	2.2	2.7	3.2
		B	F	1.3	1.5	1.7	1.9	2.2	2.6	3.1	3.6
		C	F	2.1	2.3	2.5	2.7	2.9	3.2	3.8	4.3
		D	F	3.0	3.5	4.0	4.5	5.0	5.6	6.1	6.6
		E	F	3.3	3.7	4.1	4.6	5.2	5.8	6.4	7.1
	≥1.2	A	F	1.0	1.2	1.4	1.6	2.0	2.4	2.8	3.2
		B	F	1.4	1.6	1.8	2.0	2.3	2.7	3.2	3.7
		C	F	2.2	2.4	2.6	2.8	3.0	3.4	3.9	4.4
		D	F	3.1	3.6	4.1	4.6	5.1	5.7	6.2	6.7
		E	F	3.3	3.7	4.1	4.6	5.2	5.8	6.4	7.1
Backslope 1:1	0.15	A	F	0.4	0.7	1.0	1.3	1.7	2.2	2.8	3.3
		B	F	0.7	1.0	1.3	1.6	2.0	2.5	3.1	3.6
		C	F	1.0	1.3	1.6	1.9	2.4	2.9	3.5	4.2
		D	F	2.9	3.4	3.9	4.4	4.9	5.5	6.0	6.5
		E	F	3.2	3.6	4.0	4.5	5.1	5.7	6.3	7.0
	0.3	A	F	0.7	1.0	1.3	1.6	2.0	2.4	3.1	3.8
		B	F	1.1	1.4	1.7	2.0	2.3	2.7	3.4	4.1
		C	F	1.6	1.9	2.2	2.5	2.8	3.2	3.8	4.5
		D	F	3.0	3.5	4.0	4.5	5.0	5.6	6.1	6.6
		E	F	3.3	3.7	4.1	4.6	5.1	5.8	6.4	7.1

*S = Approach Side, C = Corner, F= Traffic Face, A = S, C, and F

**TABLE HA.3 Suggested Severity Indices
Backslopes (continued)**

Object Type and Characteristics			Object Surface	Severity Index, SI							
Slope (H:V)	Height (m)	Surface Condition		Design Speed – km/h							
				50	60	70	80	90	100	110	120
Backslope 1:1 (cont.)	0.6	A	F	1.0	1.3	1.5	1.8	2.2	2.6	3.3	4.0
		B	F	1.4	1.7	1.9	2.2	2.6	3.0	3.6	4.1
		C	F	2.2	2.5	2.7	3.0	3.2	3.6	4.2	4.9
		D	F	3.0	3.5	4.0	4.5	5.0	5.6	6.1	6.6
		E	F	3.3	3.7	4.1	4.6	5.2	5.8	6.4	7.1
	≥1.2	A	F	1.1	1.4	1.6	1.9	2.3	2.8	3.4	3.9
		B	F	1.5	1.8	2.0	2.3	2.7	3.1	3.7	4.2
		C	F	2.3	2.6	2.8	3.1	3.4	3.8	4.4	4.9
		D	F	3.1	3.6	4.1	4.6	5.1	5.7	6.2	6.7
		E	F	3.3	3.7	4.1	4.6	5.2	5.8	6.4	7.1
Backslope Vertical	0.15	A	F	0.5	0.8	1.1	1.4	1.9	2.4	3.0	3.7
		B	F	0.8	1.1	1.4	1.7	2.2	2.7	3.3	4.0
		C	F	1.1	1.4	1.7	2.0	2.5	3.1	3.8	4.5
		D	F	2.8	3.3	3.8	4.3	4.8	5.4	5.9	6.4
		E	F	3.2	3.6	4.0	4.5	5.1	5.7	6.3	7.0
	0.3	A	F	0.7	1.0	1.3	1.6	2.0	2.5	3.2	3.9
		B	F	1.1	1.4	1.7	2.0	2.4	2.8	3.5	4.2
		C	F	1.6	1.9	2.2	2.5	2.9	3.3	3.9	4.6
		D	F	2.8	3.3	3.8	4.3	4.8	5.4	5.9	6.4
		E	F	3.2	3.6	4.0	4.5	5.1	5.7	6.3	7.0

*S = Approach Side, C = Corner, F= Traffic Face, A = S, C, and F

**TABLE HA.3 Suggested Severity Indices
Backslopes (continued)**

Object Type and Characteristics			Object Surface	Severity Index, SI							
Slope (H:V)	Height (m)	Surface Condition		Design Speed – km/h							
				50	60	70	80	90	100	110	120
Backslope Vertical (cont.)	0.6	A	F	0.7	1.0	1.3	1.6	2.0	2.4	3.0	3.7
		B	F	1.1	1.4	1.7	2.0	2.3	2.7	3.3	4.0
		C	F	1.6	1.9	2.2	2.5	2.8	3.2	3.8	4.3
		D	F	2.8	3.3	3.8	4.3	4.8	5.4	5.9	6.4
		E	F	3.2	3.6	4.0	4.5	5.1	5.7	6.3	7.0
	≥1.0	A	F	0.6	0.9	1.2	1.5	1.9	2.3	2.9	3.6
		B	F	1.0	1.3	1.6	1.9	2.2	2.6	3.2	3.9
		C	F	1.5	1.8	2.1	2.4	2.7	3.1	3.7	4.2
		D	F	2.8	3.3	3.8	4.3	4.8	5.4	5.9	6.4
		E	F	3.2	3.6	4.0	4.5	5.1	5.7	6.3	7.0

*S = Approach Side, C = Corner, F= Traffic Face, A = S, C, and F

**TABLE HA.4 Suggested Severity Indices
Parallel Ditches**

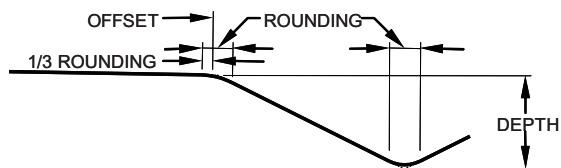

TYPICAL VEE DITCH ASSUMED IN THESE TABLES. ROUNDING IS EQUAL TO OR LESS THAN 1/4 OF THE RECOMMENDED ROUNDING.

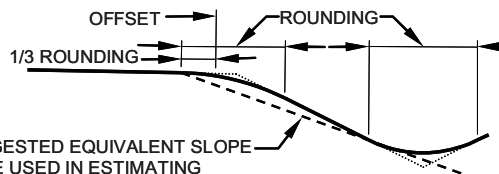

SUGGESTED EQUIVALENT SLOPE TO BE USED IN ESTIMATING SEVERITY INDEX FOR A DITCH WITH RECOMMENDED ROUNDING.

Object Type and Characteristics			Object Surface (*)	Severity Index							
Sideslope	Backslope	Depth (m)		Design Speed - km/h							
				50	60	70	80	90	100	110	120
6:1 Slope	6:1 Slope	0.15	F	0.5	0.6	0.8	0.9	1.1	1.3	1.5	1.6
		0.30	F	0.4	0.6	0.8	1.0	1.2	1.4	1.6	1.7
		0.60	F	0.6	0.7	0.9	1.0	1.2	1.5	1.7	2.0
		1.00	F	0.5	0.7	0.9	1.1	1.3	1.6	1.8	2.1
		1.20	F	0.4	0.7	0.9	1.2	1.4	1.6	1.9	2.2
	4:1 Slope	0.15	F	0.5	0.7	0.9	1.1	1.3	1.6	1.9	2.2
		0.30	F	0.4	0.7	0.9	1.2	1.4	1.7	1.9	2.2
		0.60	F	0.6	0.8	1.0	1.2	1.4	1.7	1.9	2.2
		1.00	F	0.6	0.8	1.0	1.2	1.5	1.8	2.0	2.1
		1.20	F	0.6	0.8	1.0	1.2	1.5	1.8	2.0	2.1
	3:1 Slope	0.15	F	0.7	0.9	1.1	1.3	1.6	1.9	2.2	2.5
		0.30	F	0.7	0.9	1.1	1.3	1.6	1.9	2.2	2.5
		0.60	F	0.7	0.9	1.1	1.3	1.6	1.9	2.2	2.5
		1.00	F	0.5	0.8	1.0	1.3	1.6	1.9	2.1	2.4
		1.20	F	0.5	0.8	1.0	1.3	1.6	1.9	2.1	2.4

*S = Approach Side, C = Corner, F= Traffic Face, A = S, C, and F

** For ditch configurations where the ditch bottom is 2.5 m wide or greater, the Sideslope and Backslope should be treated as independent features with offsets adjusted for intervening slopes, and the cost of the features summed.

**TABLE HA.4 Suggested Severity Indices
Parallel Ditches (continued)**

Object Type and Characteristics			Object Surface (*)	Severity Index							
Sideslope	Backslope	Depth (m)		Design Speed - km/h							
				50	60	70	80	90	100	110	120
6:1 Slope (cont.)	2:1 Slope	0.15	F	0.8	1.1	1.3	1.6	2.0	2.4	2.9	3.4
		0.30	F	0.8	1.1	1.3	1.6	2.0	2.4	2.9	3.4
		0.60	F	0.7	1.0	1.2	1.5	1.9	2.3	2.7	3.1
		1.00	F	0.6	0.9	1.1	1.4	1.8	2.2	2.5	2.8
		1.20	F	0.6	0.9	1.1	1.4	1.8	2.2	2.4	2.7
5:1 Slope	4:1 Slope	0.15	F	0.8	1.0	1.2	1.4	1.7	2.0	2.3	2.6
		0.30	F	0.9	1.1	1.3	1.5	1.7	2.0	2.3	2.6
		0.60	F	0.9	1.1	1.3	1.5	1.8	2.1	2.3	2.5
		1.00	F	0.8	1.1	1.3	1.6	1.8	2.1	2.3	2.6
		1.20	F	0.8	1.1	1.3	1.6	1.9	2.1	2.3	2.5
	3:1 Slope	0.15	F	0.8	1.0	1.2	1.4	1.6	2.0	2.3	2.7
		0.30	F	0.8	1.0	1.2	1.5	1.7	2.0	2.3	2.7
		0.60	F	0.8	1.1	1.3	1.5	1.7	2.0	2.3	2.7
		1.00	F	0.9	1.1	1.3	1.6	1.8	2.1	2.4	2.6
		1.20	F	0.9	1.1	1.4	1.6	1.8	2.1	2.4	2.6
	2:1 Slope	0.15	F	0.8	1.0	1.2	1.4	1.7	2.0	2.4	2.7
		0.30	F	0.8	1.0	1.2	1.5	1.8	2.1	2.4	2.7
		0.60	F	0.9	1.1	1.3	1.5	1.8	2.1	2.5	2.9
		1.00	F	0.9	1.5	1.3	1.6	1.8	2.2	2.5	2.8
		1.20	F	0.8	1.1	1.3	1.6	1.9	2.2	2.5	2.9

*S = Approach Side, C = Corner, F= Traffic Face, A = S, C, and F

** For ditch configurations where the ditch bottom is 2.5 m wide or greater, the Sideslope and Backslope should be treated as independent features with offsets adjusted for intervening slopes, and the cost of the features summed.

**TABLE HA.4 Suggested Severity Indices
Parallel Ditches (continued)**

Object Type and Characteristics			Object Surface (*)	Severity Index							
Sideslope	Backslope	Depth (m)		Design Speed - km/h							
				50	60	70	80	90	100	110	120
4:1 Slope	4:1 Slope	0.15	F	0.9	1.1	1.3	1.5	1.7	2.0	2.3	2.6
		0.30	F	1.0	1.2	1.4	1.6	1.8	2.1	2.3	2.6
		0.60	F	1.1	1.3	1.5	1.7	1.9	2.2	2.4	2.5
		1.00	F	1.0	1.3	1.5	1.8	2.0	2.2	2.4	2.7
		1.20	F	1.1	1.4	1.6	1.9	2.1	2.3	2.5	2.6
	3:1 Slope	0.15	F	1.0	1.2	1.4	1.6	1.9	2.3	2.7	3.1
		0.30	F	1.1	1.3	1.5	1.7	1.9	2.3	2.7	3.1
		0.60	F	1.0	1.3	1.5	1.8	2.0	2.3	2.7	3.1
		1.00	F	1.1	1.4	1.6	1.9	2.1	2.3	2.7	3.1
		1.20	F	1.1	1.4	1.7	2.0	2.1	2.3	2.7	3.1
	2:1 Slope	0.15	F	1.1	1.4	1.6	1.9	2.3	2.7	3.2	3.7
		0.30	F	1.1	1.4	1.6	1.9	2.3	2.7	3.2	3.7
		0.60	F	1.2	1.5	1.7	2.0	2.3	2.7	3.2	3.7
		1.00	F	1.2	1.5	1.7	2.0	2.3	2.7	3.1	3.5
		1.20	F	1.2	1.5	1.7	2.0	2.3	2.7	3.1	3.5
3:1 Slope	4:1 Slope	0.15	F	1.1	1.3	1.5	1.7	1.9	2.3	2.7	3.1
		0.30	F	1.3	1.5	1.7	1.9	2.1	2.4	2.8	3.2
		0.60	F	1.6	1.7	1.9	2.0	2.2	2.4	2.8	3.2
		1.00	F	1.9	2.0	2.0	2.1	2.2	2.5	2.9	3.3
		1.20	F	1.8	1.9	2.1	2.2	2.3	2.5	2.9	3.3

*S = Approach Side, C = Corner, F= Traffic Face, A = S, C, and F

** For ditch configurations where the ditch bottom is 2.5 m wide or greater, the Sideslope and Backslope should be treated as independent features with offsets adjusted for intervening slopes, and the cost of the features summed.

**TABLE HA.4 Suggested Severity Indices
Parallel Ditches (continued)**

Object Type and Characteristics			Object Surface (*)	Severity Index							
Sideslope	Backslope	Depth (m)		Design Speed - km/h							
				50	60	70	80	90	100	110	120
3:1 Slope (cont.)	3:1 Slope	0.15	F	1.1	1.4	1.6	1.9	2.2	2.6	3.1	3.6
		0.30	F	1.4	1.6	1.8	2.0	2.3	2.7	3.1	3.5
		0.60	F	1.7	1.8	2.0	2.1	2.3	2.7	3.1	3.5
		1.00	F	1.8	1.9	2.1	2.2	2.4	2.7	3.1	3.5
		1.20	F	2.0	2.1	2.1	2.2	2.4	2.8	3.2	3.6
	2:1 Slope	0.15	F	1.2	1.5	1.7	2.0	2.4	2.8	3.4	3.9
		0.30	F	1.6	1.7	1.9	2.0	2.4	2.8	3.4	3.9
		0.60	F	1.9	2.0	2.0	2.1	2.5	2.9	3.4	3.9
		1.00	F	2.0	2.1	2.1	2.2	2.5	2.9	3.4	3.9
		1.20	F	2.1	2.2	2.2	2.3	2.6	3.0	3.4	3.8
2:1 Slope	3:1 Slope	0.15	F	1.1	1.4	1.6	1.9	2.2	2.6	3.1	3.6
		0.30	F	1.5	1.7	1.9	2.1	2.4	2.8	3.2	3.6
		0.60	F	1.8	1.9	2.1	2.2	2.5	2.9	3.4	3.9
		1.00	F	1.9	2.0	2.2	2.3	2.5	2.9	3.5	4.0
		1.20	F	2.0	2.1	2.3	2.4	2.6	3.0	3.6	4.1
	2:1 Slope	0.15	F	1.2	1.5	1.7	2.0	2.4	2.8	3.4	3.9
		0.30	F	1.7	1.8	2.0	2.1	2.5	2.9	3.5	4.0
		0.60	F	1.9	2.0	2.2	2.3	2.7	3.1	3.6	4.1
		1.00	F	2.0	2.1	2.3	2.4	2.7	3.1	3.6	4.1
		1.20	F	2.1	2.2	2.4	2.5	2.8	3.2	3.7	4.2

*S = Approach Side, C = Corner, F= Traffic Face, A = S, C, and F

** For ditch configurations where the ditch bottom is 2.5 m wide or greater, the Sideslope and Backslope should be treated as independent features with offsets adjusted for intervening slopes, and the cost of the features summed.

**TABLE HA.5 Suggested Severity Indices
Approach Slopes – Negative (down)**

Object Type and Characteristics			Object Surface	Severity Index							
Slope (H:V)	Height (m)	Surface Condition(**)		Design Speed - km/h							
				50	60	70	80	90	100	110	120
Approach Slopes (neg.) 10:1	0.3	A	S	0.7	0.8	1.0	1.1	1.4	1.7	2.0	2.3
		B	S	0.9	1.0	1.2	1.3	1.4	1.6	2.2	2.9
		C	S	1.2	1.4	1.6	1.8	1.9	2.1	2.8	3.5
		D	S	2.8	3.3	3.8	4.3	4.8	5.4	5.9	6.4
		E	S	3.2	3.6	4.0	4.5	5.1	5.7	6.3	7.0
	>1	A	S	0.6	0.8	1.0	1.2	1.5	1.9	2.3	2.7
		B	S	0.8	1.0	1.2	1.4	1.7	2.1	2.6	3.1
		C	S	1.1	1.4	1.6	1.9	2.2	2.6	3.2	3.7
		D	S	2.8	3.3	3.8	4.3	4.8	5.4	5.9	6.4
		E	S	3.2	3.6	4.0	4.5	5.1	5.7	6.3	7.0
Approach Slopes (neg.) 8:1	0.3	A	S	1.3	1.4	1.6	1.7	1.9	2.1	2.4	2.7
		B	S	1.5	1.6	1.8	1.9	2.1	2.3	2.7	3.1
		C	S	1.8	2.0	2.2	2.4	2.6	2.9	3.3	3.7
		D	S	2.8	3.3	3.8	4.3	4.8	5.4	5.9	6.4
		E	S	3.2	3.6	4.0	4.5	5.1	5.7	6.3	7.0
	1	A	S	1.4	1.6	1.8	2.0	2.2	2.5	3.0	3.5
		B	S	1.6	1.8	2.0	2.2	2.4	2.7	3.3	3.8
		C	S	1.9	2.2	2.4	2.7	2.9	3.2	3.8	4.5
		D	S	2.8	3.3	3.8	4.3	4.8	5.4	5.9	6.4
		E	S	3.2	3.6	4.0	4.5	5.1	5.7	6.3	7.0
	2	A	S	1.4	1.6	1.8	2.0	2.3	2.7	3.2	3.7
		B	S	1.6	1.8	2.0	2.2	2.5	2.9	3.5	4.0
		C	S	1.9	2.2	2.4	2.7	3.0	3.4	4.0	4.7
		D	S	2.8	3.3	3.8	4.3	4.8	5.4	5.9	6.4
		E	S	3.2	3.6	4.0	4.5	5.1	5.7	6.3	7.0

*S = Approach Side, C = Corner, F= Traffic Face, A = S, C, and F

** Surface conditions are assumed to continue on surface beyond slope.

**TABLE HA.5 Suggested Severity Indices
Approach Slopes – Negative (down) (continued)**

Object Type and Characteristics			Object Surface	Severity Index							
Slope (H:V)	Height (m)	Surface Condition(**)		Design Speed - km/h							
				50	60	70	80	90	100	110	120
Approach Slopes (neg.) 8:1 (cont.)	≥4	A	S	1.4	1.6	1.8	2.0	2.3	2.7	3.3	3.8
		B	S	1.6	1.8	2.0	2.2	2.5	2.9	3.5	4.2
		C	S	1.9	2.2	2.4	2.7	3.0	3.4	4.1	4.8
		D	S	2.8	3.3	3.8	4.3	4.8	5.4	5.9	6.4
		E	S	3.2	3.6	4.0	4.5	5.1	5.7	6.3	7.0
Approach Slopes (neg.) 6:1	0.3	A	S	1.7	1.8	2.0	2.1	2.3	2.5	2.7	3.0
		B	S	1.9	2.0	2.2	2.3	2.5	2.7	3.0	3.3
		C	S	2.2	2.4	2.6	2.8	3.0	3.2	3.6	4.0
		D	S	2.8	3.3	3.8	4.3	4.8	5.4	5.9	6.4
		E	S	3.2	3.6	4.0	4.5	5.1	5.7	6.3	7.0
	1	A	S	2.1	2.3	2.5	2.7	2.9	3.3	3.7	4.1
		B	S	2.3	2.5	2.7	2.9	3.1	3.5	4.0	4.5
		C	S	2.6	2.9	3.1	3.4	3.6	4.0	4.6	5.1
		D	S	2.8	3.3	3.8	4.3	4.8	5.4	5.9	6.4
		E	S	3.2	3.6	4.0	4.5	5.1	5.7	6.3	7.0
	2	A	S	2.3	2.6	2.9	3.2	3.5	3.9	4.4	4.9
		B	S	2.5	2.8	3.1	3.4	3.7	4.1	4.7	5.2
		C	S	2.8	3.1	3.5	3.9	4.2	4.6	5.2	5.7
		D	S	2.8	3.3	3.8	4.3	4.8	5.4	5.9	6.4
		E	S	3.2	3.6	4.0	4.5	5.1	5.7	6.3	7.0
	4	A	S	2.2	2.5	2.9	3.3	3.7	4.2	4.8	5.3
		B	S	2.4	2.7	3.1	3.5	3.9	4.4	5.0	5.5
		C	S	2.7	3.1	3.5	4.0	4.4	4.9	5.5	6.0
		D	S	2.8	3.3	3.8	4.3	4.8	5.4	5.9	6.4
		E	S	3.2	3.6	4.0	4.5	5.1	5.7	6.3	7.0

*S = Approach Side, C = Corner, F= Traffic Face, A = S, C, and F

** Surface conditions are assumed to continue on surface beyond slope.

**TABLE HA.5 Suggested Severity Indices
Approach Slopes – Negative (down) (continued)**

Object Type and Characteristics			Object Surface	Severity Index							
Slope (H:V)	Height (m)	Surface Condition(**)		Design Speed - km/h							
				50	60	70	80	90	100	110	120
Approach Slopes (neg.) 6:1 (cont.)	6	A	S	2.2	2.5	2.9	3.3	3.7	4.2	4.9	5.5
		B	S	2.4	2.7	3.1	3.5	3.9	4.4	5.0	5.6
		C	S	2.7	3.1	3.5	4.0	4.4	4.9	5.5	6.0
		D	S	2.8	3.3	3.8	4.3	4.8	5.4	5.9	6.4
		E	S	3.2	3.6	4.0	4.5	5.1	5.7	6.3	7.0
	≥8	A	S	2.2	2.5	2.9	3.3	3.7	4.2	4.9	5.6
		B	S	2.4	2.7	3.1	3.5	3.9	4.4	5.0	5.7
		C	S	2.7	3.1	3.5	4.0	4.4	4.9	5.5	6.0
		D	S	2.8	3.3	3.8	4.3	4.8	5.4	5.9	6.4
		E	S	3.2	3.6	4.0	4.5	5.1	5.7	6.3	7.0
Approach Slopes (neg.) 5:1	0.3	A	S	1.8	1.9	2.1	2.2	2.4	2.6	2.8	3.1
		B	S	2.0	2.1	2.3	2.4	2.6	2.8	3.1	3.4
		C	S	2.3	2.5	2.7	2.9	3.1	3.3	3.7	4.1
		D	S	2.8	3.3	3.8	4.3	4.8	5.4	5.9	6.4
		E	S	3.2	3.6	4.0	4.5	5.1	5.7	6.3	7.0
	1	A	S	2.4	2.6	2.8	3.0	3.2	3.5	3.9	4.3
		B	S	2.6	2.8	3.0	3.2	3.4	3.7	4.2	4.6
		C	S	2.9	3.2	3.4	3.7	3.9	4.2	4.8	5.3
		D	S	2.8	3.3	3.8	4.3	4.8	5.4	5.9	6.4
		E	S	3.2	3.6	4.0	4.5	5.1	5.7	6.3	7.0
	2	A	S	2.9	3.2	3.4	3.7	3.9	4.3	4.7	5.2
		B	S	3.1	3.3	3.6	3.8	4.1	4.5	5.0	5.4
		C	S	3.3	3.6	3.9	4.3	4.6	5.0	5.5	5.9
		D	S	2.8	3.3	3.8	4.3	4.8	5.4	5.9	6.4
		E	S	3.2	3.6	4.0	4.5	5.1	5.7	6.3	7.0

*S = Approach Side, C = Corner, F= Traffic Face, A = S, C, and F

** Surface conditions are assumed to continue on surface beyond slope.

**TABLE HA.5 Suggested Severity Indices
Approach Slopes – Negative (down) (continued)**

Object Type and Characteristics			Object Surface	Severity Index							
Slope (H:V)	Height (m)	Surface Condition(**)		Design Speed - km/h							
				50	60	70	80	90	100	110	120
Approach Slopes (neg.) 5:1 (cont.)	4	A	S	3.0	3.3	3.7	4.2	4.5	4.9	5.4	5.8
		B	S	3.1	3.5	3.9	4.3	4.7	5.1	5.6	6.0
		C	S	3.4	3.8	4.3	4.8	5.1	5.6	6.1	6.5
		D	S	2.8	3.3	3.8	4.3	4.8	5.4	5.9	6.4
		E	S	3.2	3.6	4.0	4.5	5.1	5.7	6.3	7.0
	6	A	S	3.0	3.4	3.8	4.3	4.7	5.1	5.7	6.2
		B	S	3.1	3.5	4.0	4.4	4.9	5.3	5.8	6.3
		C	S	3.3	3.8	4.3	4.9	5.3	5.8	6.3	6.7
		D	S	2.8	3.3	3.8	4.3	4.8	5.4	5.9	6.4
		E	S	3.2	3.6	4.0	4.5	5.1	5.7	6.3	7.0
	8	A	S	3.0	3.4	3.9	4.4	4.8	5.3	5.9	6.4
		B	S	3.1	3.6	4.0	4.5	5.0	5.5	6.0	6.6
		C	S	3.3	3.8	4.4	4.9	5.4	6.0	6.5	6.9
		D	S	2.8	3.3	3.8	4.3	4.8	5.4	5.9	6.4
		E	S	3.2	3.6	4.0	4.5	5.1	5.7	6.3	7.0
	≥10	A	S	3.0	3.4	3.9	4.4	4.9	5.4	6.1	6.7
		B	S	3.1	3.6	4.0	4.5	5.1	5.6	6.2	6.8
		C	S	3.3	3.8	4.4	4.9	5.5	6.0	6.5	7.0
		D	S	2.8	3.3	3.8	4.3	4.8	5.4	5.9	6.4
		E	S	3.2	3.6	4.0	4.5	5.1	5.7	6.3	7.0
Approach Slopes (neg.) 4:1	0.3	A	S	1.9	2.0	2.2	2.3	2.5	2.7	2.9	3.2
		B	S	2.1	2.2	2.4	2.5	2.7	2.9	3.2	3.5
		C	S	2.4	2.6	2.8	3.0	3.2	3.4	3.8	4.2
		D	S	2.8	3.3	3.8	4.3	4.8	5.4	5.9	6.4
		E	S	3.2	3.6	4.0	4.5	5.1	5.7	6.3	7.0

*S = Approach Side, C = Corner, F= Traffic Face, A = S, C, and F

** Surface conditions are assumed to continue on surface beyond slope.

**TABLE HA.5 Suggested Severity Indices
Approach Slopes – Negative (down) (continued)**

Object Type and Characteristics			Object Surface	Severity Index							
Slope (H:V)	Height (m)	Surface Condition(**)		Design Speed - km/h							
				50	60	70	80	90	100	110	120
Approach Slopes (neg.) 4:1 (cont.)	1	A	S	2.6	2.8	3.0	3.2	3.4	3.6	4.0	4.4
		B	S	2.8	3.0	3.2	3.4	3.6	3.9	4.3	4.7
		C	S	3.1	3.4	3.6	3.9	4.1	4.4	4.9	5.4
		D	S	2.8	3.3	3.8	4.3	4.8	5.4	5.9	6.4
		E	S	3.2	3.6	4.0	4.5	5.1	5.7	6.3	7.0
	2	A	S	3.5	3.7	3.9	4.1	4.3	4.6	5.0	5.4
		B	S	3.6	3.8	4.0	4.2	4.5	4.8	5.2	5.6
		C	S	3.8	4.1	4.3	4.6	5.0	5.3	5.7	6.1
		D	S	2.8	3.3	3.8	4.3	4.8	5.4	5.9	6.4
		E	S	3.2	3.6	4.0	4.5	5.1	5.7	6.3	7.0
	4	A	S	3.7	4.1	4.5	5.0	5.2	5.5	5.9	6.3
		B	S	3.8	4.2	4.6	5.1	5.4	5.7	6.1	6.5
		C	S	4.0	4.5	5.0	5.5	5.8	6.2	6.6	7.0
		D	S	2.8	3.3	3.8	4.3	4.8	5.4	5.9	6.4
		E	S	3.2	3.6	4.0	4.5	5.1	5.7	6.3	7.0
	6	A	S	3.7	4.2	4.7	5.2	5.6	6.0	6.4	6.8
		B	S	3.8	4.3	4.8	5.3	5.8	6.2	6.6	7.0
		C	S	3.9	4.5	5.1	5.7	6.1	6.6	7.0	7.4
		D	S	2.8	3.3	3.8	4.3	4.8	5.4	5.9	6.4
		E	S	3.2	3.6	4.0	4.5	5.1	5.7	6.3	7.0
8	A	S	3.7	4.3	4.8	5.4	5.9	6.4	6.8	7.2	
	B	S	3.8	4.4	4.9	5.5	6.1	6.6	7.0	7.4	
	C	S	3.9	4.5	5.2	5.8	6.4	7.0	7.4	7.8	
	D	S	2.8	3.3	3.8	4.3	4.8	5.4	5.9	6.4	
	E	S	3.2	3.6	4.0	4.5	5.1	5.7	6.3	7.0	

*S = Approach Side, C = Corner, F= Traffic Face, A = S, C, and F

** Surface conditions are assumed to continue on surface beyond slope.

**TABLE HA.5 Suggested Severity Indices
Approach Slopes – Negative (down) (continued)**

Object Type and Characteristics			Object Surface	Severity Index							
Slope (H:V)	Height (m)	Surface Condition(**)		Design Speed - km/h							
				50	60	70	80	90	100	110	120
Approach Slopes (neg.) 4:1 (cont.)	10	A	S	3.7	4.3	4.8	5.4	6.0	6.6	7.2	7.7
		B	S	3.8	4.4	4.9	5.5	6.2	6.8	7.3	7.8
		C	S	3.9	4.5	5.2	5.8	6.5	7.1	7.5	7.9
		D	S	2.8	3.3	3.8	4.3	4.8	5.4	5.9	6.4
		E	S	3.2	3.6	4.0	4.5	5.1	5.7	6.3	7.0
	≥14	A	S	3.7	4.3	4.8	5.4	6.0	6.6	7.2	7.9
		B	S	3.8	4.4	4.9	5.5	6.2	6.8	7.4	7.9
		C	S	3.9	4.5	5.2	5.8	6.5	7.1	7.5	7.9
		D	S	2.8	3.3	3.8	4.3	4.8	5.4	5.9	6.4
		E	S	3.2	3.6	4.0	4.5	5.1	5.7	6.3	7.0
Approach Slopes (neg.) 3:1	0.3	A	S	1.9	2.0	2.2	2.3	2.5	2.7	2.9	3.2
		B	S	2.1	2.2	2.4	2.5	2.7	2.9	3.2	3.5
		C	S	2.4	2.6	2.8	3.0	3.2	3.4	3.8	4.2
		D	S	2.8	3.3	3.8	4.3	4.8	5.4	5.9	6.4
		E	S	3.2	3.6	4.0	4.5	5.1	5.7	6.3	7.0
	1	A	S	2.7	2.9	3.1	3.3	3.5	3.7	4.0	4.3
		B	S	2.7	3.0	3.2	3.5	3.6	3.9	4.3	4.7
		C	S	3.1	3.4	3.6	3.9	4.1	4.4	4.9	5.4
		D	S	2.8	3.3	3.8	4.3	4.8	5.4	5.9	6.4
		E	S	3.2	3.6	4.0	4.5	5.1	5.7	6.3	7.0
	2	A	S	3.8	4.0	4.2	4.4	4.6	4.8	5.1	5.4
		B	S	3.9	4.1	4.3	4.5	4.7	5.0	5.3	5.6
		C	S	4.2	4.4	4.6	4.8	5.0	5.3	5.6	5.9
		D	S	2.8	3.3	3.8	4.3	4.8	5.4	5.9	6.4
		E	S	3.2	3.6	4.0	4.5	5.1	5.7	6.3	7.0

*S = Approach Side, C = Corner, F= Traffic Face, A = S, C, and F

** Surface conditions are assumed to continue on surface beyond slope.

**TABLE HA.5 Suggested Severity Indices
Approach Slopes – Negative (down) (continued)**

Object Type and Characteristics			Object Surface	Severity Index							
Slope (H:V)	Height (m)	Surface Condition(**)		Design Speed - km/h							
				50	60	70	80	90	100	110	120
Approach Slopes (neg.) 3:1 (cont.)	4	A	S	4.8	5.0	5.2	5.4	5.7	6.0	6.2	6.5
		B	S	4.9	5.1	5.3	5.5	5.9	6.2	6.4	6.7
		C	S	5.1	5.3	5.5	5.7	6.1	6.4	6.8	7.2
		D	S	2.8	3.3	3.8	4.3	4.8	5.4	5.9	6.4
		E	S	3.2	3.6	4.0	4.5	5.1	5.7	6.3	7.0
	6	A	S	4.9	5.3	5.7	6.1	6.4	6.7	6.9	7.2
		B	S	5.0	5.4	5.8	6.2	6.6	6.9	7.1	7.4
		C	S	5.2	5.6	5.9	6.3	6.7	7.0	7.3	7.7
		D	S	2.8	3.3	3.8	4.3	4.8	5.4	5.9	6.4
		E	S	3.2	3.6	4.0	4.5	5.1	5.7	6.3	7.0
	8	A	S	5.0	5.6	6.1	6.7	7.0	7.3	7.5	7.8
		B	S	5.1	5.7	6.2	6.8	7.2	7.5	7.7	8.0
		C	S	5.2	5.8	6.3	6.9	7.3	7.6	7.8	8.1
		D	S	2.8	3.3	3.8	4.3	4.8	5.4	5.9	6.4
		E	S	3.2	3.6	4.0	4.5	5.1	5.7	6.3	7.0
	10	A	S	4.9	5.6	6.3	7.0	7.4	7.8	8.2	8.6
		B	S	5.0	5.7	6.4	7.1	7.5	7.9	8.3	8.7
		C	S	5.1	5.8	6.5	7.2	7.6	8.0	8.4	8.8
		D	S	2.8	3.3	3.8	4.3	4.8	5.4	5.9	6.4
		E	S	3.2	3.6	4.0	4.5	5.1	5.7	6.3	7.0
	14	A	S	4.9	5.6	6.3	7.0	7.5	7.9	8.3	8.7
		B	S	5.0	5.7	6.4	7.1	7.5	7.9	8.3	8.7
		C	S	5.1	5.8	6.5	7.2	7.6	8.0	8.4	8.8
		D	S	2.8	3.3	3.8	4.3	4.8	5.4	5.9	6.4
		E	S	3.2	3.6	4.0	4.5	5.1	5.7	6.3	7.0

*S = Approach Side, C = Corner, F= Traffic Face, A = S, C, and F

** Surface conditions are assumed to continue on surface beyond slope.

**TABLE HA.5 Suggested Severity Indices
Approach Slopes – Negative (down) (continued)**

Object Type and Characteristics			Object Surface	Severity Index							
Slope (H:V)	Height (m)	Surface Condition(**)		Design Speed - km/h							
				50	60	70	80	90	100	110	120
Approach Slopes (neg.) 3:1 (cont.)	≥18	A	S	4.9	5.6	6.3	7.0	7.5	8.0	8.4	8.8
		B	S	5.0	5.7	6.4	7.1	7.6	8.0	8.4	8.8
		C	S	5.1	5.8	6.5	7.2	7.6	8.0	8.4	8.8
		D	S	2.8	3.3	3.8	4.3	4.8	5.4	5.9	6.4
		E	S	3.2	3.6	4.0	4.5	5.1	5.7	6.3	7.0
Approach Slopes (neg.) 2:1	0.3	A	S	1.9	2.0	2.2	2.3	2.5	2.7	2.9	3.2
		B	S	2.1	2.2	2.4	2.5	2.7	2.9	3.2	3.5
		C	S	2.4	2.6	2.8	3.0	3.2	3.4	3.8	4.2
		D	S	2.8	3.3	3.8	4.3	4.8	5.4	5.9	6.4
		E	S	3.2	3.6	4.0	4.5	5.1	5.7	6.3	7.0
	1	A	S	2.9	3.0	3.2	3.3	3.5	3.7	4.0	4.3
		B	S	2.9	3.1	3.3	3.5	3.6	3.9	4.3	4.7
		C	S	3.3	3.5	3.7	3.9	4.1	4.4	4.9	5.4
		D	S	2.8	3.3	3.8	4.3	4.8	5.4	5.9	6.4
		E	S	3.2	3.6	4.0	4.5	5.1	5.7	6.3	7.0
	2	A	S	4.1	4.2	4.4	4.5	4.7	4.9	5.1	5.4
		B	S	4.1	4.2	4.4	4.5	4.7	5.0	5.3	5.6
		C	S	4.2	4.4	4.6	4.8	5.0	5.3	5.6	5.9
		D	S	2.8	3.3	3.8	4.3	4.8	5.4	5.9	6.4
		E	S	3.2	3.6	4.0	4.5	5.1	5.7	6.3	7.0
	4	A	S	5.5	5.6	5.6	5.7	5.9	6.2	6.4	6.5
		B	S	5.5	5.6	5.6	5.7	6.0	6.3	6.5	6.6
		C	S	5.6	5.7	5.7	5.8	6.1	6.4	6.6	6.7
		D	S	2.8	3.3	3.8	4.3	4.8	5.4	5.9	6.4
		E	S	3.2	3.6	4.0	4.5	5.1	5.7	6.3	7.0

*S = Approach Side, C = Corner, F= Traffic Face, A = S, C, and F

** Surface conditions are assumed to continue on surface beyond slope.

**TABLE HA.5 Suggested Severity Indices
Approach Slopes – Negative (down) (continued)**

Object Type and Characteristics			Object Surface	Severity Index							
Slope (H:V)	Height (m)	Surface Condition(**)		Design Speed - km/h							
				50	60	70	80	90	100	110	120
Approach Slopes (neg.) 2:1 (cont.)	6	A	S	6.0	6.2	6.4	6.6	6.8	7.1	7.3	7.4
		B	S	6.0	6.2	6.4	6.6	6.9	7.2	7.4	7.5
		C	S	6.1	6.3	6.5	6.7	7.0	7.3	7.5	7.6
		D	S	2.8	3.3	3.8	4.3	4.8	5.4	5.9	6.4
		E	S	3.2	3.6	4.0	4.5	5.1	5.7	6.3	7.0
	8	A	S	6.5	6.8	7.1	7.4	7.6	7.9	8.1	8.2
		B	S	6.5	6.8	7.1	7.4	7.7	8.0	8.2	8.3
		C	S	6.6	6.9	7.2	7.5	7.8	8.1	8.3	8.4
		D	S	2.8	3.3	3.8	4.3	4.8	5.4	5.9	6.4
		E	S	3.2	3.6	4.0	4.5	5.1	5.7	6.3	7.0
	10	A	S	7.0	7.4	7.8	8.3	8.5	8.7	8.9	9.0
		B	S	7.0	7.4	7.8	8.3	8.5	8.8	9.0	9.1
		C	S	7.1	7.5	7.9	8.4	8.6	8.9	9.1	9.2
		D	S	2.8	3.3	3.8	4.3	4.8	5.4	5.9	6.4
		E	S	3.2	3.6	4.0	4.5	5.1	5.7	6.3	7.0
	14	A	S	7.2	7.6	8.0	8.5	8.7	9.0	9.2	9.3
		B	S	7.2	7.6	8.0	8.5	8.7	9.0	9.2	9.3
		C	S	7.2	7.6	8.0	8.5	8.7	9.0	9.2	9.3
		D	S	2.8	3.3	3.8	4.3	4.8	5.4	5.9	6.4
		E	S	3.2	3.6	4.0	4.5	5.1	5.7	6.3	7.0
	18	A	S	7.3	7.7	8.1	8.6	8.9	9.1	9.3	9.4
		B	S	7.3	7.7	8.1	8.6	8.9	9.1	9.3	9.4
		C	S	7.3	7.7	8.1	8.6	8.9	9.1	9.3	9.4
		D	S	2.8	3.3	3.8	4.3	4.8	5.4	5.9	6.4
		E	S	3.2	3.6	4.0	4.5	5.1	5.7	6.3	7.0

*S = Approach Side, C = Corner, F= Traffic Face, A = S, C, and F

** Surface conditions are assumed to continue on surface beyond slope.

**TABLE HA.5 Suggested Severity Indices
Approach Slopes – Negative (down) (continued)**

Object Type and Characteristics			Object Surface	Severity Index							
Slope (H:V)	Height (m)	Surface Condition(**)		Design Speed - km/h							
				50	60	70	80	90	100	110	120
Approach Slopes (neg.) 2:1 (cont.)	≥22	A	S	7.2	7.7	8.2	8.7	8.9	9.1	9.3	9.4
		B	S	7.2	7.7	8.2	8.7	8.9	9.1	9.3	9.4
		C	S	7.2	7.7	8.2	8.7	8.9	9.1	9.3	9.4
		D	S	2.8	3.3	3.8	4.3	4.8	5.4	5.9	6.4
		E	S	3.2	3.6	4.0	4.5	5.1	5.7	6.3	7.0
Approach Slopes (neg.) 1½:1	0.3	A	S	1.9	2.0	2.2	2.3	2.5	2.7	2.9	3.2
		B	S	2.1	2.2	2.4	2.5	2.7	2.9	3.2	3.5
		C	S	2.4	2.6	2.8	3.0	3.2	3.4	3.8	4.2
		D	S	2.8	3.3	3.8	4.3	4.8	5.4	5.9	6.4
		E	S	3.2	3.6	4.0	4.5	5.1	5.7	6.3	7.0
	1	A	S	2.9	3.0	3.2	3.3	3.5	3.7	4.0	4.3
		B	S	2.9	3.1	3.3	3.5	3.6	3.9	4.3	4.7
		C	S	3.3	3.5	3.7	3.9	4.1	4.4	4.9	5.4
		D	S	2.8	3.3	3.8	4.3	4.8	5.4	5.9	6.4
		E	S	3.2	3.6	4.0	4.5	5.1	5.7	6.3	7.0
	2	A	S	4.1	4.2	4.4	4.5	4.7	4.9	5.1	5.4
		B	S	4.1	4.2	4.4	4.5	4.7	5.0	5.3	5.6
		C	S	4.2	4.4	4.6	4.8	5.0	5.3	5.6	5.9
		D	S	2.8	3.3	3.8	4.3	4.8	5.4	5.9	6.4
		E	S	3.2	3.6	4.0	4.5	5.1	5.7	6.3	7.0

*S = Approach Side, C = Corner, F= Traffic Face, A = S, C, and F

** Surface conditions are assumed to continue on surface beyond slope.

**TABLE HA.5 Suggested Severity Indices
Approach Slopes – Negative (down) (continued)**

Object Type and Characteristics			Object Surface	Severity Index							
Slope (H:V)	Height (m)	Surface Condition(**)		Design Speed - km/h							
				50	60	70	80	90	100	110	120
Approach Slopes (neg.) 1½:1 (cont.)	4	A	S	5.6	5.7	5.7	5.8	6.0	6.2	6.4	6.5
		B	S	5.6	5.7	5.7	5.8	6.0	6.3	6.5	6.6
		C	S	5.5	5.6	5.8	5.9	6.1	6.4	6.6	6.7
		D	S	2.8	3.3	3.8	4.3	4.8	5.4	5.9	6.4
		E	S	3.2	3.6	4.0	4.5	5.1	5.7	6.3	7.0
	6	A	S	6.3	6.5	6.6	6.7	6.9	7.1	7.4	7.4
		B	S	6.3	6.5	6.6	6.7	6.9	7.2	7.4	7.5
		C	S	6.3	6.5	6.6	6.7	6.9	7.2	7.4	7.5
		D	S	2.8	3.3	3.8	4.3	4.8	5.4	5.9	6.4
		E	S	3.2	3.6	4.0	4.5	5.1	5.7	6.3	7.0
	8	A	S	7.0	7.2	7.4	7.6	7.8	8.0	8.2	8.3
		B	S	7.0	7.2	7.4	7.6	7.8	8.0	8.2	8.3
		C	S	7.0	7.2	7.4	7.6	7.8	8.0	8.2	8.3
		D	S	2.8	3.3	3.8	4.3	4.8	5.4	5.9	6.4
		E	S	3.2	3.6	4.0	4.5	5.1	5.7	6.3	7.0
	10	A	S	7.9	8.2	8.5	8.8	8.9	8.9	9.1	9.2
		B	S	7.9	8.2	8.5	8.8	8.9	8.9	9.1	9.2
		C	S	7.9	8.2	8.5	8.8	8.9	8.9	9.1	9.2
		D	S	2.8	3.3	3.8	4.3	4.8	5.4	5.9	6.4
		E	S	3.2	3.6	4.0	4.5	5.1	5.7	6.3	7.0

*S = Approach Side, C = Corner, F= Traffic Face, A = S, C, and F

** Surface conditions are assumed to continue on surface beyond slope.

**TABLE HA.5 Suggested Severity Indices
Approach Slopes – Negative (down) (continued)**

Object Type and Characteristics			Object Surface	Severity Index							
Slope (H:V)	Height (m)	Surface Condition(**)		Design Speed - km/h							
				50	60	70	80	90	100	110	120
Approach Slopes (neg.) 1½:1 (cont.)	14	A	S	8.3	8.6	8.8	9.1	9.2	9.3	9.5	9.6
		B	S	8.3	8.6	8.8	9.1	9.2	9.3	9.5	9.6
		C	S	8.3	8.6	8.8	9.1	9.2	9.3	9.5	9.6
		D	S	2.8	3.3	3.8	4.3	4.8	5.4	5.9	6.4
		E	S	3.2	3.6	4.0	4.5	5.1	5.7	6.3	7.0
	18	A	S	8.5	8.8	9.0	9.3	9.4	9.5	9.5	9.5
		B	S	8.5	8.8	9.0	9.3	9.4	9.5	9.6	9.6
		C	S	8.5	8.8	9.0	9.3	9.4	9.5	9.6	9.6
		D	S	2.8	3.3	3.8	4.3	4.8	5.4	5.9	6.4
		E	S	3.2	3.6	4.0	4.5	5.1	5.7	6.3	7.0
	≥22	A	S	8.6	8.9	9.1	9.4	9.5	9.5	9.6	9.6
		B	S	8.6	8.9	9.1	9.4	9.5	9.5	9.6	9.6
		C	S	8.6	8.9	9.1	9.4	9.5	9.5	9.6	9.6
		D	S	2.8	3.3	3.8	4.3	4.8	5.4	5.9	6.4
		E	S	3.2	3.6	4.0	4.5	5.1	5.7	6.3	7.0

*S = Approach Side, C = Corner, F= Traffic Face, A = S, C, and F

** Surface conditions are assumed to continue on surface beyond slope.

**TABLE HA.6 Suggested Severity Indices
Approach Slopes – Vertical Drop w/ and w/o Water Present**

Object Type and Characteristics			Object Surface (*)	Severity Index							
Slope (H:V)	Height (m)	Water Depth (m)		Design Speed – km/h							
				50	60	70	80	90	100	110	120
Approach Slopes Vertical Drop	0	0	S	0.1	0.2	0.2	0.3	0.4	0.5	0.7	0.8
		1	S	2.2	2.4	2.6	2.8	3.0	3.2	3.4	3.7
		2	S	4.3	4.6	4.8	5.1	5.3	5.6	5.8	6.1
		4	S	6.0	6.2	6.4	6.6	6.8	7.0	7.2	7.5
		≥6	S	7.5	7.7	7.9	8.1	8.3	8.4	8.6	8.7
	0.3	0	S	1.9	2.0	2.2	2.3	2.5	2.7	2.9	3.2
		1	S	2.6	2.9	3.1	3.4	3.6	3.9	4.1	4.4
		2	S	4.3	4.6	4.9	5.2	5.6	5.9	6.3	6.7
		4	S	6.0	6.3	6.6	6.9	7.1	7.4	7.6	7.9
		≥6	S	7.9	8.0	8.2	8.3	8.5	8.7	8.9	9.0
	1.0	0	S	2.9	3.0	3.2	3.3	3.5	3.7	4.0	4.3
		1	S	3.2	3.4	3.6	3.8	4.0	4.2	4.5	4.8
		2	S	5.4	5.6	5.8	6.0	6.3	6.6	6.8	7.1
		4	S	6.5	6.8	7.0	7.3	7.5	7.7	7.9	8.2
		≥6	S	8.0	8.1	8.3	8.4	8.6	8.8	9.0	9.1
	2.0	0	S	4.1	4.2	4.4	4.5	4.7	4.9	5.1	5.4
		1	S	4.2	4.4	4.6	4.8	5.0	5.2	5.4	5.7
		2	S	6.5	6.6	6.8	6.9	7.1	7.3	7.5	7.6
		4	S	7.3	7.4	7.6	7.7	7.9	8.1	8.3	8.4
		≥6	S	8.1	8.2	8.4	8.5	8.7	8.9	9.1	9.2
	4.0	0	S	5.7	5.8	5.8	5.9	6.0	6.2	6.4	6.5
		1	S	5.7	5.8	6.0	6.1	6.2	6.4	6.7	7.0
		2	S	7.2	7.3	7.5	7.6	7.8	8.0	8.2	8.3
		4	S	7.8	7.9	8.1	8.2	8.4	8.6	8.8	8.9
		≥6	S	8.4	8.5	8.7	8.8	9.0	9.2	9.4	9.5
≥8.0	Any Depth	S	Use Values From Sideslopes - Vertical								

*S = Approach Side, C = Corner, F= Traffic Face, A = S, C, and F

**TABLE HA.7 Suggested Severity Indices
Approach Slopes – Positive (up) ****

Object Type and Characteristics			Object Surface (*)	Severity Index							
Slope (H:V)	Height (m)	Surface Condition		Design Speed – km/h							
				50	60	70	80	90	100	110	120
Approach Slopes (pos.) 10:1	0.15	A	S	0.3	0.4	0.6	0.7	0.9	1.1	1.3	1.6
		B	S	0.5	0.6	0.8	0.9	1.1	1.3	1.5	1.8
		C	S	0.9	1.0	1.2	1.3	1.5	1.7	2.0	2.3
		D	S	2.8	3.3	3.8	4.3	4.8	5.4	5.9	6.4
		E	S	3.2	3.6	4.0	4.5	5.1	5.7	6.3	7.0
	0.3	A	S	0.4	0.5	0.7	0.8	1.2	1.5	1.9	2.3
		B	S	0.6	0.7	0.9	1.0	1.4	1.7	2.1	2.5
		C	S	0.8	1.0	1.2	1.4	1.8	2.1	2.5	2.9
		D	S	2.8	3.3	3.8	4.3	4.8	5.4	5.9	6.4
		E	S	3.2	3.6	4.0	4.5	5.1	5.7	6.3	7.0
	0.6	A	S	0.4	0.5	0.7	0.8	1.2	1.6	2.0	2.4
		B	S	0.6	0.7	0.9	1.0	1.4	1.8	2.2	2.6
		C	S	0.8	1.0	1.2	1.4	1.8	2.2	2.6	3.0
		D	S	2.8	3.3	3.8	4.3	4.8	5.4	5.9	6.4
		E	S	3.2	3.6	4.0	4.5	5.1	5.7	6.3	7.0
Approach Slopes (pos.) 8:1	0.15	A	S	0.3	0.4	0.6	0.7	0.9	1.1	1.3	1.6
		B	S	0.5	0.6	0.8	0.9	1.1	1.3	1.5	1.8
		C	S	0.9	1.0	1.2	1.3	1.5	1.7	2.0	2.3
		D	S	2.8	3.3	3.8	4.3	4.8	5.4	5.9	6.4
		E	S	3.2	3.6	4.0	4.5	5.1	5.7	6.3	7.0

* S = Approach Side, C = Corner, F= Traffic Face, A = S, C, and F

** The condition addressed in this table is a relatively simple one where the vehicle encounters an approach upward slope that connects to a relatively level and wide surface at its upper limit. Transitions between sideslope or backslopes and approaching slopes are not addressed, nor is the condition where a vehicle might vault over a dike or a narrow intersecting roadway. Developing SIs for the conditions not addressed will require special analysis and engineering judgement.

**TABLE HA.7 Suggested Severity Indices
Approach Slopes – Positive (up) ** (continued)**

Object Type and Characteristics			Object Surface (*)	Severity Index							
Slope (H:V)	Height (m)	Surface Condition		Design Speed – km/h							
				50	60	70	80	90	100	110	120
Approach Slopes (pos.) 8:1 (cont.)	0.3	A	S	0.4	0.6	0.8	1.0	1.5	2.0	2.2	2.5
		B	S	0.6	0.8	1.0	1.2	1.7	2.1	2.4	2.7
		C	S	0.8	1.1	1.3	1.6	2.1	2.5	2.8	3.1
		D	S	2.8	3.3	3.8	4.3	4.8	5.4	5.9	6.4
		E	S	3.2	3.6	4.0	4.5	5.1	5.7	6.3	7.0
	0.6	A	S	0.3	0.6	0.9	1.2	1.7	2.1	2.3	2.4
		B	S	0.5	0.8	1.0	1.3	1.8	2.2	2.4	2.7
		C	S	0.8	1.1	1.4	1.7	2.2	2.6	2.8	3.1
		D	S	2.8	3.3	3.8	4.3	4.8	5.4	5.9	6.4
		E	S	3.2	3.6	4.0	4.5	5.1	5.7	6.3	7.0
	1	A	S	0.3	0.6	0.9	1.2	1.7	2.1	2.3	2.6
		B	S	0.5	0.8	1.1	1.4	1.8	2.2	2.5	2.8
		C	S	0.7	1.0	1.4	1.8	2.2	2.6	2.9	3.2
		D	S	2.8	3.3	3.8	4.3	4.8	5.4	5.9	6.4
		E	S	3.2	3.6	4.0	4.5	5.1	5.7	6.3	7.0
Approach Slopes (pos.) 6:1	0.15	A	S	0.3	0.4	0.6	0.7	0.9	1.1	1.3	1.6
		B	S	0.5	0.6	0.8	0.9	1.1	1.3	1.5	1.8
		C	S	0.7	0.9	1.1	1.3	1.5	1.8	2.0	2.3
		D	S	2.8	3.3	3.8	4.3	4.8	5.4	5.9	6.4
		E	S	3.2	3.6	4.0	4.5	5.1	5.7	6.3	7.0
	0.3	A	S	0.5	0.8	1.2	1.6	2.0	2.3	2.6	2.9
		B	S	0.7	1.0	1.4	1.8	2.1	2.4	2.8	3.2
		C	S	1.0	1.3	1.7	2.1	2.4	2.7	3.1	3.5
		D	S	2.8	3.3	3.8	4.3	4.8	5.4	5.9	6.4
		E	S	3.2	3.6	4.0	4.5	5.1	5.7	6.3	7.0

* S = Approach Side, C = Corner, F= Traffic Face, A = S, C, and F

** See note at the beginning of this table for limitation and description of condition.

**TABLE HA.7 Suggested Severity Indices
Approach Slopes – Positive (up) ** (continued)**

Object Type and Characteristics			Object Surface (*)	Severity Index							
Slope (H:V)	Height (m)	Surface Condition		Design Speed – km/h							
				50	60	70	80	90	100	110	120
Approach Slopes (pos.) 6:1 (cont.)	0.6	A	S	0.5	0.9	1.3	1.8	2.1	2.4	2.7	3.0
		B	S	0.8	1.1	1.5	1.9	2.2	2.5	2.9	3.3
		C	S	1.0	1.4	1.8	2.3	2.5	2.8	3.2	3.6
		D	S	2.8	3.3	3.8	4.3	4.8	5.4	5.9	6.4
		E	S	3.2	3.6	4.0	4.5	5.1	5.7	6.3	7.0
	1	A	S	0.4	0.9	1.4	1.9	2.2	2.5	2.8	3.1
		B	S	0.7	1.1	1.5	2.0	2.3	2.6	3.0	3.4
		C	S	0.9	1.4	1.9	2.4	2.6	2.9	3.3	3.7
		D	S	2.8	3.3	3.8	4.3	4.8	5.4	5.9	6.4
		E	S	3.2	3.6	4.0	4.5	5.1	5.7	6.3	7.0
Approach Slopes (pos.) 4:1	0.15	A	S	0.2	0.4	0.6	0.8	1.0	1.2	1.4	1.7
		B	S	0.4	0.6	0.8	1.0	1.2	1.4	1.6	1.9
		C	S	0.6	0.9	1.1	1.4	1.6	1.8	2.1	2.4
		D	S	2.8	3.3	3.8	4.3	4.8	5.4	5.9	6.4
		E	S	3.2	3.6	4.0	4.5	5.1	5.7	6.3	7.0
	0.3	A	S	1.3	1.6	1.9	2.2	2.6	3.0	3.3	3.6
		B	S	1.5	1.8	2.0	2.3	2.7	3.1	3.5	3.9
		C	S	1.8	2.1	2.3	2.6	3.0	3.4	3.8	4.2
		D	S	2.8	3.3	3.8	4.3	4.8	5.4	5.9	6.4
		E	S	3.2	3.6	4.0	4.5	5.1	5.7	6.3	7.0
	0.6	A	S	1.6	1.9	2.1	2.4	2.8	3.2	3.5	3.8
		B	S	1.7	2.0	2.2	2.5	2.9	3.3	3.6	3.9
		C	S	2.2	2.4	2.6	2.8	3.2	3.6	3.9	4.2
		D	S	2.8	3.3	3.8	4.3	4.8	5.4	5.9	6.4
		E	S	3.2	3.6	4.0	4.5	5.1	5.7	6.3	7.0

* S = Approach Side, C = Corner, F= Traffic Face, A = S, C, and F

** See note at the beginning of this table for limitation and description of condition.

**TABLE HA.7 Suggested Severity Indices
Approach Slopes – Positive (up) ** (continued)**

Object Type and Characteristics			Object Surface (*)	Severity Index							
Slope (H:V)	Height (m)	Surface Condition		Design Speed – km/h							
				50	60	70	80	90	100	110	120
Approach Slopes (pos.) 4:1 (cont)	1	A	S	1.6	1.9	2.1	2.4	2.8	3.2	3.6	4.0
		B	S	1.7	2.0	2.2	2.5	2.9	3.3	3.7	4.1
		C	S	2.2	2.4	2.6	2.8	3.2	3.6	4.0	4.4
		D	S	2.8	3.3	3.8	4.3	4.8	5.4	5.9	6.4
		E	S	3.2	3.6	4.0	4.5	5.1	5.7	6.3	7.0
Approach Slopes (pos.) 3:1	0.15	A	S	0.2	0.4	0.6	0.8	1.0	1.2	1.4	1.7
		B	S	0.4	0.6	0.8	1.0	1.2	1.4	1.6	1.9
		C	S	0.6	0.9	1.1	1.4	1.6	1.8	2.1	2.4
		D	S	2.8	3.3	3.8	4.3	4.8	5.4	5.9	6.4
		E	S	3.2	3.6	4.0	4.5	5.1	5.7	6.3	7.0
	0.3	A	S	1.8	2.1	2.4	2.7	3.1	3.5	3.9	4.3
		B	S	1.9	2.2	2.5	2.8	3.2	3.6	4.0	4.4
		C	S	2.2	2.5	2.8	3.1	3.5	3.9	4.2	4.5
		D	S	2.8	3.3	3.8	4.3	4.8	5.4	5.9	6.4
		E	S	3.2	3.6	4.0	4.5	5.1	5.7	6.3	7.0
	0.6	A	S	1.8	2.1	2.5	2.9	3.3	3.7	4.1	4.5
		B	S	1.9	2.2	2.6	3.0	3.4	3.8	4.2	4.6
		C	S	2.2	2.5	2.9	3.3	3.7	4.0	4.4	4.8
		D	S	2.8	3.3	3.8	4.3	4.8	5.4	5.9	6.4
		E	S	3.2	3.6	4.0	4.5	5.1	5.7	6.3	7.0
	1	A	S	1.9	2.2	2.6	3.0	3.4	3.8	4.2	4.6
		B	S	2.0	2.3	2.7	3.1	3.5	3.9	4.3	4.7
		C	S	2.1	2.5	2.9	3.4	3.8	4.1	4.5	4.9
		D	S	2.8	3.3	3.8	4.3	4.8	5.4	5.9	6.4
		E	S	3.2	3.6	4.0	4.5	5.1	5.7	6.3	7.0

* S = Approach Side, C = Corner, F= Traffic Face, A = S, C, and F

** See note at the beginning of this table for limitation and description of condition.

**TABLE HA.7 Suggested Severity Indices
Approach Slopes – Positive (up) ** (continued)**

Object Type and Characteristics			Object Surface (*)	Severity Index							
Slope (H:V)	Height (m)	Surface Condition		Design Speed – km/h							
				50	60	70	80	90	100	110	120
Approach Slopes (pos.) 2:1	0.15	A	S	0.4	0.5	0.7	0.8	1.0	1.2	1.4	1.7
		B	S	0.6	0.7	0.9	1.0	1.2	1.4	1.6	1.9
		C	S	0.8	1.0	1.2	1.4	1.6	1.8	2.1	2.4
		D	S	2.8	3.3	3.8	4.3	4.8	5.4	5.9	6.4
		E	S	3.2	3.6	4.0	4.5	5.1	5.7	6.3	7.0
	0.3	A	S	2.1	2.5	2.9	3.4	3.9	4.4	4.8	5.2
		B	S	2.2	2.6	3.0	3.5	4.0	4.5	4.9	5.3
		C	S	2.3	2.8	3.3	3.8	4.2	4.7	5.1	5.5
		D	S	2.8	3.3	3.8	4.3	4.8	5.4	5.9	6.4
		E	S	3.2	3.6	4.0	4.5	5.1	5.7	6.3	7.0
	0.6	A	S	2.5	2.8	3.2	3.6	4.1	4.6	5.0	5.4
		B	S	2.6	2.9	3.3	3.7	4.2	4.7	5.1	5.5
		C	S	2.8	3.1	3.5	3.9	4.4	4.9	5.3	5.7
		D	S	2.8	3.3	3.8	4.3	4.8	5.4	5.9	6.4
		E	S	3.2	3.6	4.0	4.5	5.1	5.7	6.3	7.0
	1	A	S	2.6	2.9	3.3	3.7	4.2	4.7	5.1	5.5
		B	S	2.7	3.0	3.4	3.8	4.3	4.8	5.2	5.6
		C	S	2.9	3.2	3.6	4.0	4.5	4.9	5.3	5.7
		D	S	2.8	3.3	3.8	4.3	4.8	5.4	5.9	6.4
		E	S	3.2	3.6	4.0	4.5	5.1	5.7	6.3	7.0

* S = Approach Side, C = Corner, F= Traffic Face, A = S, C, and F

** See note at the beginning of this table for limitation and description of condition.

**TABLE HA.7 Suggested Severity Indices
Approach Slopes – Positive (up) ** (continued)**

Object Type and Characteristics			Object Surface (*)	Severity Index							
Slope (H:V)	Height (m)	Surface Condition		Design Speed – km/h							
				50	60	70	80	90	100	110	120
Approach Slopes (pos.) 1:1	0.15	A	S	0.4	0.5	0.7	0.8	1.0	1.3	1.5	1.8
		B	S	0.6	0.7	0.9	1.0	1.2	1.5	1.7	2.0
		C	S	0.8	1.0	1.2	1.4	1.6	1.9	2.1	2.4
		D	S	2.8	3.3	3.8	4.3	4.8	5.4	5.9	6.4
		E	S	3.2	3.6	4.0	4.5	5.1	5.7	6.3	7.0
	0.3	A	S	2.9	3.3	3.7	4.2	4.7	5.3	5.8	6.3
		B	S	3.0	3.4	3.8	4.3	4.8	5.4	5.8	6.2
		C	S	3.2	3.6	4.0	4.5	5.0	5.5	5.9	6.3
		D	S	3.2	3.6	4.0	4.5	5.0	5.5	5.9	6.4
		E	S	3.2	3.6	4.0	4.5	5.1	5.7	6.3	7.0
	0.6	A	S	3.0	3.5	4.0	4.5	5.0	5.6	6.2	6.7
		B	S	3.1	3.6	4.1	4.6	5.1	5.6	6.2	6.7
		C	S	3.3	3.8	4.3	4.8	5.2	5.7	6.3	6.8
		D	S	3.3	3.8	4.3	4.8	5.2	5.7	6.3	6.8
		E	S	3.3	3.8	4.3	4.8	5.2	5.7	6.3	7.0
	1	A	S	3.1	3.6	4.1	4.6	5.1	5.7	6.3	6.8
		B	S	3.2	3.7	4.2	4.7	5.2	5.7	6.3	6.8
		C	S	3.4	3.9	4.4	4.9	5.3	5.8	6.4	6.9
		D	S	3.4	3.9	4.4	4.9	5.3	5.8	6.4	6.9
		E	S	3.4	3.9	4.4	4.9	5.3	5.8	6.4	6.9

* S = Approach Side, C = Corner, F= Traffic Face, A = S, C, and F

** See note at the beginning of this table for limitation and description of condition.

**TABLE HA.7 Suggested Severity Indices
Approach Slopes – Positive (up) ** (continued)**

Object Type and Characteristics			Object Surface (*)	Severity Index							
Slope (H:V)	Height (m)	Surface Condition		Design Speed – km/h							
				50	60	70	80	90	100	110	120
Approach Slopes (pos.) ½:1	0.15	A	S	0.4	0.5	0.7	0.8	1.0	1.3	1.5	1.8
		B	S	0.6	0.7	0.9	1.0	1.2	1.5	1.7	2.0
		C	S	0.8	1.0	1.2	1.4	1.6	1.9	2.1	2.4
		D	S	2.8	3.3	3.8	4.3	4.8	5.4	5.9	6.4
		E	S	3.2	3.6	4.0	4.5	5.1	5.7	6.3	7.0
	0.3	A	S	2.4	2.9	3.4	3.9	4.3	4.8	5.3	5.8
		B	S	2.5	3.0	3.5	4.0	4.4	4.9	5.4	5.9
		C	S	2.7	3.2	3.7	4.2	4.6	5.1	5.5	5.9
		D	S	2.8	3.3	3.8	4.3	4.8	5.4	5.9	6.4
		E	S	3.2	3.6	4.0	4.5	5.1	5.7	6.3	7.0
	0.6	A	S	2.6	3.1	3.6	4.1	4.6	5.2	5.6	6.0
		B	S	2.7	3.2	3.7	4.2	4.7	5.3	5.7	6.1
		C	S	2.9	3.4	3.9	4.4	4.9	5.4	5.8	6.2
		D	S	2.9	3.4	3.9	4.4	4.9	5.4	5.9	6.4
		E	S	3.2	3.6	4.0	4.5	5.1	5.7	6.3	7.0
	1	A	S	2.7	3.2	3.7	4.2	4.7	5.3	5.7	6.1
		B	S	2.8	3.3	3.8	4.3	4.8	5.4	5.8	6.2
		C	S	3.0	3.5	4.0	4.5	5.0	5.5	5.9	6.3
		D	S	3.0	3.5	4.0	4.5	5.0	5.5	5.9	6.3
		E	S	3.2	3.6	4.0	4.5	5.1	5.7	6.3	7.0

* S = Approach Side, C = Corner, F= Traffic Face, A = S, C, and F

** See note at the beginning of this table for limitation and description of condition.

**TABLE HA.8 Suggested Severity Indices
Traffic Barriers**

Object Type and Characteristics	Object Surface (*)	Severity Index							
		Design Speed – km/h							
		50	60	70	80	90	100	110	120
Longitudinal Traffic Barriers									
Uniform Section									
Basic SI ** For all currently accepted barriers, guardrails, bridgerails, median barriers, apply the basic SI to the percentage of impacts estimated to be contained by the barrier. For that percentage of impacts estimated to penetrate, an SI appropriate for the shielded hazard should be used to adjust the effective barrier SI.	F	1.9	2.0	2.2	2.3	2.5	2.7	3.0	3.3
Basic SI Cable on strong posts (adjust for estimated penetrations)	F	2.0	2.2	2.4	2.6	2.8	3.1	3.4	3.7
Average SI Weak post W-Beam	F	-	2.4	2.5	3.0	3.2	3.3	3.5	-
Average SI Strong post W-Beam	F	-	2.6	2.8	3.1	3.4	3.8	4.3	-
Average SI Concrete barriers	F	-	2.3	2.4	2.7	3.1	3.6	4.3	-
For walls and parapets with irregular surfaces estimate SIs by referring to vertical backslopes	F	-	-	-	-	-	-	-	-
Guardrail to Parapet Transitions									
Treat the same as currently acceptable longitudinal barriers if transition meets crash test acceptance requirements and adjust for estimated penetrations	F	1.9	2.0	2.2	2.3	2.5	2.7	3.0	3.3

* S = Approach Side, C = Corner, F= Traffic Face, A = S, C, and F

** SI information for High tension cable systems are currently not available. Designer should based the SI values on the in-service experience of the system in similar application in consultation with staff from INFTRA.

**TABLE HA.8 Suggested Severity Indices
Traffic Barriers (continued)**

Object Type and Characteristics	Object Surface (*)	Severity Index							
		Design Speed – km/h							
		50	60	70	80	90	100	110	120
Guardrail to Parapet Transitions (cont.)									
Uniform Section									
For substandard transitions consider a section of the face of the approach guardrail as having the severity of a fixed object. This section of barrier would nominally be parapet of a continuous barrier face, thus the corner and side SIs would be zero.									
Examples: Standard, strong-post, w-beam guardrail, blocked out with two spaces at 0.95-m and full-strength attachment to parapet	F	0.1m @ 1.8	0.1m @ 2.0	0.3m @ 2.2	0.4m @ 2.4	0.7m @ 2.6	1.1m @ 2.9	1.6m @ 3.2	2.0m @ 3.5
Standard, strong-post, w-beam guardrail, blocked out, width 1.9-m post spacing and no connection to parapet	F	0.4m @ 2.0	0.7m @ 2.3	1.1m @ 2.5	1.5m @ 2.8	2.1m @ 3.2	2.7m @ 3.5	3.5m @ 3.9	4.2m @ 4.3
Terminals (approach end except where noted)									
Stand-up w-beam, unanchored, with no safety treatment and no flare. The first few feet of the unanchored rail will have diminished effectiveness and have a higher SI than the remainder of the guardrail. The values given here for that section of guardrail may require adjustment for penetration to the shielded object.	C&S	4.1	4.3	4.5	4.7	5.0	5.3	5.6	5.9
	F	1.0m @ 2.2	1.6m @ 2.5	2.1m @ 2.7	2.7m @ 3.0	3.3m @ 3.2	4.1m @ 3.4	5.2m @ 3.8	6.3m @ 4.2
Turned-down w-beam (TEB 3.12)	C&S	2.7	2.9	3.1	3.3	3.7	4.0	4.3	4.6
	F	5.5m @ 2.8	5.5m @ 3.0	5.5m @ 3.2	5.5m @ 3.4	5.5m @ 3.8	5.5m @ 4.1	5.5m @ 4.4	5.5m @ 4.7

* S = Approach Side, C = Corner, F= Traffic Face, A = S, C, and F

** Dimension above “@” sign is length of device to be analyzed using the noted severity index..

**TABLE HA.8 Suggested Severity Indices
Traffic Barriers (continued)**

Object Type and Characteristics	Object Surface (*)	Severity Index							
		Design Speed – km/h							
		50	60	70	80	90	100	110	120
Terminals (cont.)									
Concrete Flare and Turn Down Treatment (RDG-B6.2)	C&S	3.0	3.3	3.5	3.8	4.2	4.6	5.0	5.4
Exit end (treat as fixed object)	C&S	2.7	3.1	3.5	4.0	4.5	5.0	5.5	6.0
CAT-350, ET-Plus, FLEAT	C&S	2.0	2.2	2.4	2.6	2.9	3.2	3.5	3.8
	F	2m @ 2.1	2m @ 2.3	2m @ 2.5	2m @ 2.7	2m @ 2.9	2m @ 3.2	2m @ 3.5	2m @ 3.8
Buried in backslope – The SI components for this type of terminal will be dependent on the configuration of the backslope, the ditch cross section, the terminus flare rate, and the conditions reachable by vehicles penetrating the terminal area. Values given here assume a 3:1 backslope paralleling the roadway at the point of burial, top of guardrail parallels the roadway at point of burial, top of guardrail parallels the roadway grade, the ditch is modified to provide a berm for carrying the flair guardrails, grading approaching the berm is sufficiently gentle to have minimal effect on approach vehicle trajectory, and the guardrail at flare rates to 50, 60, 70, 80, 90, 100, 110, and 120 km/h are 9:1, 10:1, 11:1, 12:1, 13:1, 14:1, 15:1 and 16:1 respectively.	C&S	0.6	0.7	0.9	1.0	1.2	1.5	1.7	2.0
	F	4m @ 2.0	4m @ 2.2	4m @ 2.4	4m @ 2.6	4m @ 2.8	4m @ 3.1	4m @ 3.3	4m @ 3.6

* S = Approach Side, C = Corner, F= Traffic Face, A = S, C, and F

** Dimension above “@” sign is length of device to be analyzed using the noted severity index..

**TABLE HA.8 Suggested Severity Indices
Traffic Barriers (continued)**

Object Type and Characteristics	Object Surface (*)	Severity Index							
		Design Speed – km/h							
		50	60	70	80	90	100	110	120
Terminals (Approach end except where noted) (cont.)									
Three-cable, steel post barrier terminal with 5.5-m turndown and non-snag release feature for exit end impacts, Brifen cable terminal, and Gibraltar cable terminal	C&S	1.9	2.0	2.2	2.3	2.5	2.7	3.0	3.3
	F	3m @ 2.0	3m @ 2.1	3m @ 2.3	3m @ 2.4	3m @ 2.6	3m @ 2.8	3m @ 3.1	3m @ 3.4
Crash Cushions									
Redirecting - Design meets Recommended performance requirements including TRACC and Quadguard systems.	C&S	2.1	2.2	2.4	2.5	2.7	3.0	3.3	3.6
	F	1.9	2.0	2.2	2.3	2.5	2.8	3.1	3.4
Non-Redirecting – Design meets recommended performance requirements, sand barrels have recommended 0.75-m shadow offset at rear of array – treat a section of the face at the rear of the array as having higher SI than that assigned to the remainder of the crash cushion. Consider section as part of a continuous barrier face. Thus the corner and side SIs of the section equal zero.	C&S	1.9	2.0	2.2	2.3	2.5	2.8	3.1	3.4
	F	0.2m @ 3.3	0.3m @ 3.6	0.5m @ 3.9	1.0m @ 4.2	1.5m @ 4.6	2.3m @ 5.1	2.7m @ 5.6	3.3m @ 6.1

* S = Approach Side, C = Corner, F= Traffic Face, A = S, C, and F

** Dimension above “@” sign is length of device to be analyzed using the noted severity index..

**TABLE HA.9 Suggested Severity Indices
Fixed Objects**

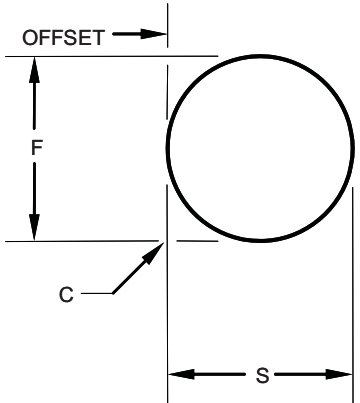
Object Type and Characteristics		Object Surface (*)	Severity Index								
			Design Speed – km/h								
			50	60	70	80	90	100	110	120	
Round Fixed Object: 	Diameter equal to 0.5 m	S	3.0	3.4	3.8	4.3	4.8	5.4	6.0	6.5	
		C	3.4	3.8	4.2	4.7	5.2	5.8	6.5	7.2	
		F	2.6	3.0	3.4	3.9	4.4	4.9	5.3	5.7	
	Diameter equal to 1 m	S	2.8	3.3	3.8	4.3	4.8	5.3	5.9	6.4	
		C	3.3	3.7	4.1	4.6	5.1	5.7	6.4	7.1	
		F	2.5	2.9	3.3	3.8	4.3	4.7	5.0	5.3	
	Diameter equal to or greater than 2 m	S	2.7	3.2	3.7	4.2	4.7	5.3	5.9	6.4	
		C	3.2	3.6	4.0	4.5	5.0	5.6	6.3	7.0	
		F	2.6	2.9	3.3	3.7	4.2	4.7	5.2	5.7	
Rectangular Fixed Object: Width of approach side equal to 0.5m Face parallel to roadway, sides are perpendicular.	Height = 0.15 m	S	0.2	0.3	0.5	0.6	0.7	0.8	0.9	0.9	
		C	0.2	0.3	0.5	0.6	0.7	0.8	0.9	0.9	
		F	0.4	0.5	0.7	0.8	1.0	1.2	1.4	1.5	
	Height = 0.3 m	S	2.8	3.3	3.8	4.3	4.8	5.4	5.9	6.4	
		C	2.8	3.3	3.8	4.3	4.8	5.4	5.9	6.4	
		F	1.9	2.0	2.2	2.3	2.5	2.7	2.9	3.2	
	Height = 0.5 m	S	3.2	3.6	4.0	4.5	5.1	5.7	6.3	6.8	
		C	3.2	3.6	4.0	4.5	5.1	5.7	6.3	6.8	
		F	1.9	2.0	2.2	2.3	2.5	2.7	2.9	3.2	
	Height = 0.6 m	S	3.4	3.8	4.2	4.7	5.2	5.8	6.5	7.2	
		C	3.4	3.8	4.2	4.7	5.2	5.8	6.5	7.2	
		F	1.9	2.0	2.2	2.3	2.5	2.7	2.9	3.2	
	Height > 1.0 m	S	3.4	3.9	4.4	4.9	5.4	6.0	6.7	7.4	
		C	3.4	3.9	4.4	4.9	5.4	6.0	6.7	7.4	
		F	1.9	2.0	2.2	2.3	2.5	2.7	2.9	3.2	

* S = Approach Side, C = Corner, F= Traffic Face, A = S, C, and F

**TABLE HA.9 Suggested Severity Indices
Fixed Objects (continued)**

Object Type and Characteristics		Object Surface (*)	Severity Index							
			Design Speed – km/h							
			50	60	70	80	90	100	110	120
Rectangular Fixed Object: Width of approach side is 1.25 m. Face is parallel to roadway, sides are perpendicular.	Height = 0.15 m	S	0.5	0.6	0.8	0.9	1.1	1.3	1.5	1.8
		C	0.5	0.6	0.8	0.9	1.1	1.3	1.5	1.8
		F	0.4	0.5	0.7	0.8	1.0	1.2	1.4	1.5
	Height = 0.3 m	S	2.6	3.2	3.7	4.3	4.8	5.3	5.8	6.3
		C	2.8	3.3	3.8	4.3	4.8	5.4	5.9	6.4
		F	1.9	2.0	2.2	2.3	2.5	2.7	2.9	3.2
	Height = 0.5 m	S	3.0	3.5	4.0	4.5	5.0	5.6	6.2	6.7
		C	3.2	3.6	4.0	4.5	5.1	5.7	6.3	6.8
		F	1.9	2.0	2.2	2.3	2.5	2.7	2.9	3.2
	Height = 0.6 m	S	3.1	3.6	4.1	4.6	5.1	5.7	6.4	7.1
		C	3.4	3.8	4.2	4.7	5.2	5.8	6.5	7.2
		F	1.9	2.0	2.2	2.3	2.5	2.7	2.9	3.2
	Height > 1.0 m	S	3.3	3.8	4.3	4.8	5.3	5.9	6.6	7.3
		C	3.4	3.9	4.4	4.9	5.4	6.0	6.7	7.4
		F	1.9	2.0	2.2	2.3	2.5	2.7	2.9	3.2
Rectangular Fixed Object: Width of approach side is 2 m or greater. Face is parallel to traffic and sides are perpendicular.	Height = 0.15 m	S	0.5	0.7	0.9	1.1	1.3	1.6	1.9	2.2
		C	0.5	0.7	0.9	1.1	1.3	1.6	1.9	2.2
		F	0.4	0.5	0.7	0.8	1.0	1.2	1.4	1.5
	Height = 0.3 m	S	2.5	3.1	3.6	4.2	4.7	5.3	5.8	6.3
		C	2.8	3.3	3.8	4.3	4.8	5.4	5.9	6.4
		F	1.9	2.0	2.2	2.3	2.5	2.7	3.0	3.3
	Height = 0.5 m	S	2.9	3.4	3.9	4.4	4.9	5.5	6.1	6.6
		C	3.2	3.6	4.0	4.5	5.1	5.7	6.3	6.8
		F	1.9	2.0	2.2	2.3	2.5	2.7	3.0	3.3
	Height = 0.6 m	S	2.8	3.4	4.1	4.7	5.1	5.6	6.3	7.0
		C	3.5	3.8	4.2	4.6	5.2	5.8	6.5	7.2
		F	1.9	2.0	2.2	2.3	2.5	2.7	3.0	3.3
	Height > 1.0 m	S	3.2	3.7	4.2	4.7	5.2	5.8	6.5	7.2
		C	3.4	3.9	4.4	4.9	5.4	6.0	6.7	7.4
		F	1.9	2.0	2.2	2.3	2.5	2.7	2.9	3.3

* S = Approach Side, C = Corner, F= Traffic Face, A = S, C, and F

**TABLE HA.9 Suggested Severity Indices
Fixed Objects (continued)**

Object Type and Characteristics		Object Surface (*)	Severity Index							
			Design Speed – km/h							
			50	60	70	80	90	100	110	120
Trees	Diameter = 50 mm	A	0.2	0.3	0.3	0.4	0.5	0.5	0.7	0.8
	Diameter = 100 mm	A	1.0	1.1	1.1	1.2	1.3	1.5	1.7	2.0
	Diameter = 150 mm	A	2.5	2.6	2.6	2.7	2.9	3.0	3.2	3.3
	Diameter = 200 mm	A	3.2	3.5	3.7	4.0	4.3	4.6	5.0	5.4
	Diameter = 250 mm	A	3.2	3.6	4.0	4.5	5.0	5.6	6.2	6.7
	Diameter = 300 mm	A	3.3	3.7	4.1	4.6	5.1	5.7	6.4	7.1
	Diameter > 300 mm	A	3.4	3.8	4.2	4.7	5.2	5.8	6.5	7.2
Utility Poles (Wooden)	Diameter = 200 mm	A	3.1	3.4	3.6	3.9	4.2	4.5	4.9	5.3
	Diameter = 250 mm	A	3.1	3.5	3.9	4.4	4.9	5.5	6.1	6.6
	Diameter = 300 mm	A	3.3	3.7	4.1	4.6	5.1	5.6	6.3	7.0
	Diameter > 300 mm	A	3.4	3.8	4.2	4.7	5.2	5.8	6.5	7.2
Breakaway Supports with 35 km/h crash test velocity change of:	1.5 meters/second	A	0.9	1.0	1.2	1.3	1.4	1.6	1.8	1.9
	3.0 meters/second	A	1.4	1.5	1.7	1.8	1.9	2.1	2.3	2.6
	4.5 meters/second	A	1.8	2.0	2.2	2.4	2.5	2.7	2.9	3.2
	6.1 meters/second	A	2.3	2.5	2.7	2.9	3.1	3.3	3.5	3.8
	7.6 meters/second	A	2.9	3.1	3.3	3.5	3.7	3.9	4.1	4.4

* S = Approach Side, C = Corner, F= Traffic Face, A = S, C, and F

**TABLE HA.10 Suggested Severity Indices
Culverts**

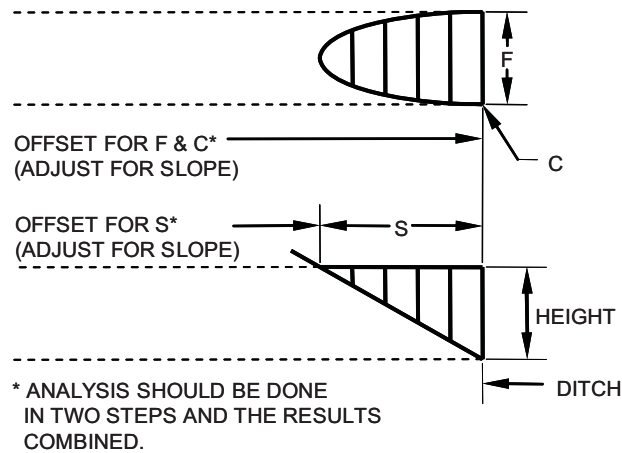

Object Type and Characteristics		Object Surface (*)	Severity Index							
			Design Speed – km/h							
Description	Height		50	60	70	80	90	100	110	120
Culvert Ends: Culvert Axis Transverse to traffic Culvert End Type A	0.3 m	S	0.4	0.5	0.7	0.8	0.9	1.1	1.3	1.4
		C	1.4	1.7	2.0	2.3	2.7	3.1	3.4	3.7
		F	2.3	2.6	2.9	3.2	3.4	3.7	4.0	4.3
	0.5 m	S	0.6	0.7	0.9	1.0	1.2	1.4	1.6	1.7
		C	1.7	2.1	2.5	3.0	3.4	3.8	4.3	4.8
		F	2.1	2.4	2.8	3.2	3.4	3.6	4.0	4.4
	0.6 m	S	1.5	1.8	2.2	2.6	2.9	3.2	3.6	4.0
		C	1.9	2.5	3.2	3.8	4.3	4.8	5.3	5.8
		F	2.2	2.5	2.8	3.1	3.3	3.6	4.0	4.4
	1.0 m	S	2.1	2.5	2.9	3.4	3.8	4.2	4.7	5.2
		C	2.0	2.6	3.1	3.7	4.3	4.9	5.5	6.0
		F	2.2	2.5	2.8	3.1	3.5	3.8	4.1	4.4
	1.2 m	S	2.6	3.0	3.4	3.9	4.3	4.8	5.4	5.9
		C	1.6	2.2	2.9	3.5	4.2	4.8	5.4	6.1
		F	2.1	2.5	2.9	3.4	3.8	4.1	4.3	4.6
	1.8 m	S	2.9	3.3	3.7	4.2	4.7	5.2	5.8	6.5
		C	1.1	1.8	2.5	3.2	3.9	4.5	5.1	5.8
		F	1.6	2.1	2.6	3.1	3.4	3.8	4.2	4.6
	2.4 m	S	3.0	3.5	4.0	4.5	5.0	5.6	6.2	6.7
		C	0.2	1.0	1.9	2.7	3.4	4.1	4.7	5.4
		F	1.5	1.9	2.3	2.8	3.3	3.7	4.1	4.5

* S = Approach Side, C = Corner, F= Traffic Face, A = S, C, and F

**TABLE HA.10 Suggested Severity Indices
Culverts (continued)**

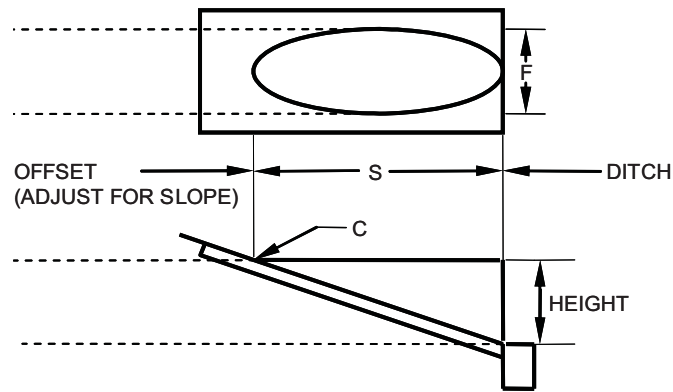

Object Type and Characteristics		Object Surface (*)	Severity Index							
			Design Speed – km/h							
Description	Height		50	60	70	80	90	100	110	120
Culvert Ends: Culvert Axis Transverse to traffic (cont.) Culvert End Type B	0.3 m	S,C,&F	0.2	0.3	0.5	0.6	0.8	1.0	1.3	1.6
	0.5 m	S,C,&F	0.4	0.5	0.7	0.8	1.2	1.6	2.0	2.4
	0.6 m	S,C,&F	0.3	0.6	0.9	1.2	1.7	2.1	2.3	2.6
	1.0 m	S,C,&F	0.5	1.0	1.5	2.0	2.3	2.6	3.0	3.4
	1.2 m	S,C,&F	1.5	1.8	2.1	2.4	2.8	3.2	3.6	4.0
	1.8 m	S,C,&F	1.9	2.3	2.7	3.2	3.7	4.1	4.5	4.9
	2.4 m	S,C,&F	2.5	2.9	3.3	3.8	4.3	4.8	5.3	5.8

* S = Approach Side, C = Corner, F= Traffic Face, A = S, C, and F

**TABLE HA.10 Suggested Severity Indices
Culverts (continued)**

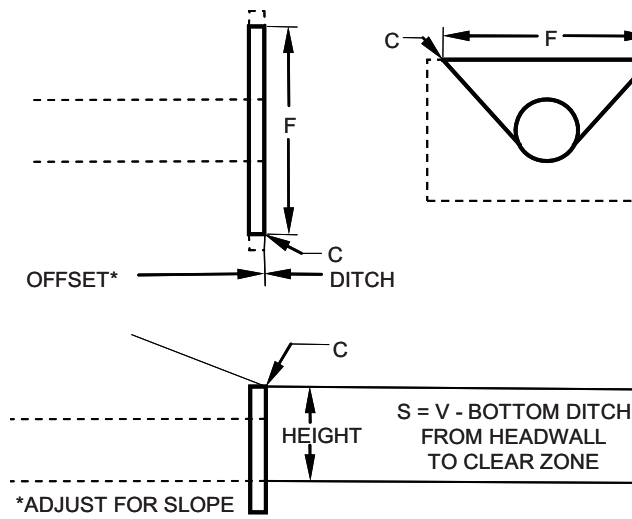

Object Type and Characteristics		Object Surface (*)	Severity Index							
			Design Speed – km/h							
Description	Height		50	60	70	80	90	100	110	120
Culvert Ends: Culvert Axis Transverse to traffic (cont.) Culvert End Type C	0.3 m	C,S	2.4	2.7	3.0	3.3	3.6	3.9	4.3	4.7
		F	2.1	2.4	2.7	3.0	3.3	3.6	3.8	4.1
	0.5 m	C,S	3.0	3.3	3.5	3.8	4.1	4.4	4.6	4.9
		F	2.6	2.9	3.1	3.4	3.6	3.9	4.1	4.4
	0.6 m	C,S	3.2	3.5	3.8	4.1	4.4	4.7	5.0	5.3
		F	2.8	3.1	3.3	3.6	3.8	4.1	4.3	4.6
	1.0 m	C,S	3.9	4.2	4.5	4.8	5.0	5.3	5.5	5.8
		F	3.0	3.3	3.6	3.9	4.1	4.4	4.6	4.9
	1.2 m	C,S	4.3	4.5	4.7	4.9	5.2	5.5	5.8	6.1
		F	3.5	3.7	3.9	4.1	4.3	4.6	4.8	5.1
	1.8 m	C,S	4.8	5.0	5.2	5.4	5.7	6.0	6.3	6.6
		F	4.0	4.2	4.4	4.6	4.8	5.1	5.3	5.6
	2.4 m	C,S	5.2	5.4	5.6	5.8	6.0	6.3	6.6	6.9
		F	4.6	4.7	4.9	5.0	5.2	5.5	5.7	6.0

* S = Approach Side, C = Corner, F = Traffic Face, A = S, C, and F

**TABLE HA.10 Suggested Severity Indices
Culverts (continued)**

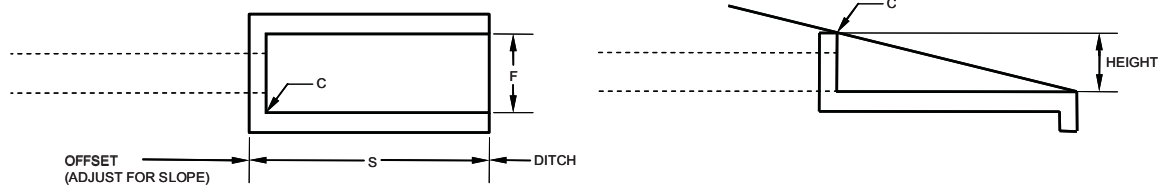

Object Type and Characteristics		Object Surface (*)	Severity Index							
			Design Speed – km/h							
Description	Height		50	60	70	80	90	100	110	120
Culvert Ends: Culvert Axis Transverse to traffic Culvert End Type D	0.3 m	S,C,&F	1.2	1.4	1.6	1.8	2.0	2.3	2.6	2.9
	0.5 m	S,C,&F	1.5	1.7	1.9	2.1	2.4	2.8	3.5	4.2
	0.6 m	S,C,&F	1.6	1.9	2.1	2.4	2.8	3.1	3.3	3.6
	1.0 m	S,C,&F	1.7	2.1	2.5	3.0	3.2	3.5	3.8	4.1
	1.2 m	S,C,&F	2.4	2.7	3.0	3.3	3.6	3.9	4.2	4.5
	1.8 m	S,C,&F	3.0	3.3	3.6	3.9	4.3	4.6	4.9	5.2
	2.4 m	S,C,&F	3.3	3.6	4.0	4.4	4.8	5.1	5.5	5.9

* S = Approach Side, C = Corner, F= Traffic Face, A = S, C, and F

**TABLE HA.10 Suggested Severity Indices
Culverts (continued)**

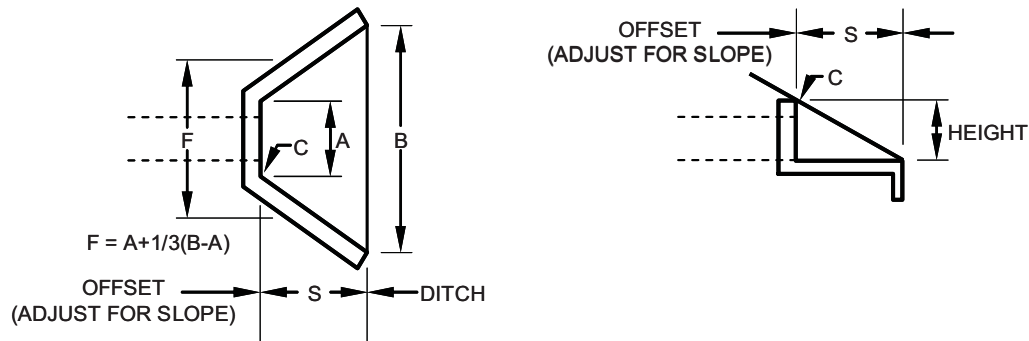

Object Type and Characteristics		Object Surface (*)	Severity Index							
			Design Speed – km/h							
Description	Height		50	60	70	80	90	100	110	120
Culvert Ends: Culvert Axis Transverse to traffic Culvert End Type E	0.3 m	S	1.8	2.1	2.3	2.6	2.9	3.1	3.3	3.4
		C	2.2	2.5	2.8	3.1	3.4	3.7	3.9	4.2
		F	1.8	2.0	2.2	2.4	2.7	3.0	3.2	3.3
	0.5 m	S	2.5	2.7	2.9	3.1	3.2	3.4	3.7	4.0
		C	3.0	3.2	3.4	3.6	3.8	4.1	4.3	4.6
		F	2.3	2.5	2.7	2.9	3.1	3.3	3.5	3.8
	0.6 m	S	2.6	2.8	3.0	3.2	3.4	3.7	4.0	4.3
		C	3.0	3.3	3.5	3.8	4.0	4.3	4.6	4.9
		F	2.3	2.6	2.8	3.1	3.3	3.5	3.8	4.1
	1.0 m	S	2.7	3.0	3.4	3.8	4.0	4.2	4.4	4.5
		C	3.3	3.6	4.0	4.4	4.6	4.8	5.0	5.3
		F	2.7	3.0	3.3	3.6	3.8	4.0	4.2	4.3
	1.2 m	S	3.3	3.5	3.7	3.9	4.1	4.3	4.6	4.9
		C	3.9	4.1	4.3	4.5	4.7	5.0	5.3	5.6
		F	3.1	3.3	3.5	3.7	3.9	4.1	4.4	4.7
	1.8 m	S	3.9	4.0	4.2	4.3	4.5	4.8	5.1	5.4
		C	4.4	4.6	4.8	5.0	5.2	5.5	5.8	6.1
		F	3.7	3.8	4.0	4.1	4.3	4.6	4.9	5.2
	2.4 m	S	4.3	4.4	4.6	4.7	4.9	5.1	5.2	5.2
		C	5.0	5.1	5.3	5.4	5.6	5.8	6.0	6.1
		F	4.1	4.2	4.4	4.5	4.7	4.9	5.0	5.0

* S = Approach Side, C = Corner, F= Traffic Face, A = S, C, and F

** The ditch beyond the culvert end is also an obstacle and should be accounted for in an economic analysis and in locating guardrail.